

Removal and Installation of Steering Wheel

Job No.

46—2

Removal:

1. Disconnect the battery cable at the negative terminal.
2. Turn the steering wheel to the right until the right steering wheel spoke is about the width of one spoke beyond the vertical and the bore in the steering column jacket is exactly in line with the opening in the contact plate (see Fig. 46—1/3).

Then use a piece of welding rod approximately 20 cm long to press the trademark plate off the steering wheel from below (Fig. 46—2/1).

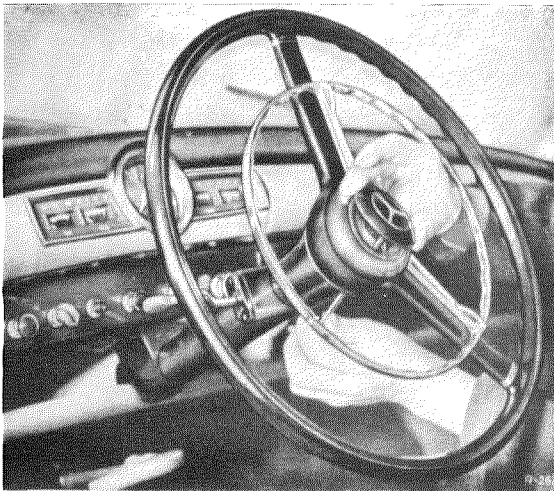

Fig. 46—2/1

3. Pull out the cotter pin for the horn ring adjusting nut and unscrew the adjusting nut. Take off the horn ring together with contact disk, compression spring, insulating plate and contact cup (see Fig. 46—2/4).
4. Back out the three fixing screws (1) for the contact plate (Fig. 46—2/2), lift up the contact plate and disconnect the wiring harness.
5. Tap up the locking plate for the hexagon nut with which the steering wheel is fixed, and back out the hexagon nut approximately 2—3 turns.

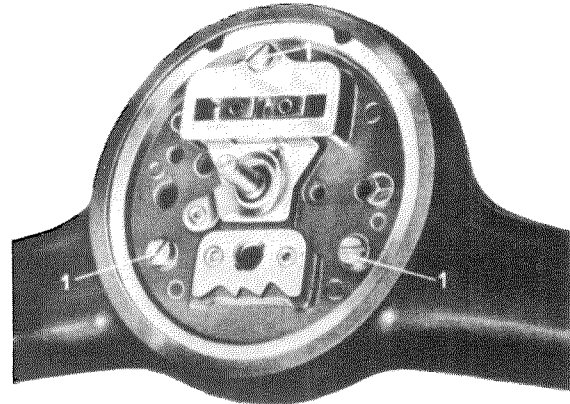

Fig. 46—2/2

6. Place Puller 120 589 01 33 so that the cables lie freely in the recesses of the pressure block. Insert the jaws of the puller into the recesses in the hub of the steering wheel and screw in the spindle until the puller is exerting a definite pressure.
7. Then tap the spindle head of the puller several times with a hammer, so that the cone of the steering wheel comes away from the cone of the steering tube (Fig. 46—2/3).

Caution! Do not try to loosen the steering wheel merely by tightening hard on the spindle (i. e., without tapping it with a hammer), since this might cause the steering wheel hub to break off.

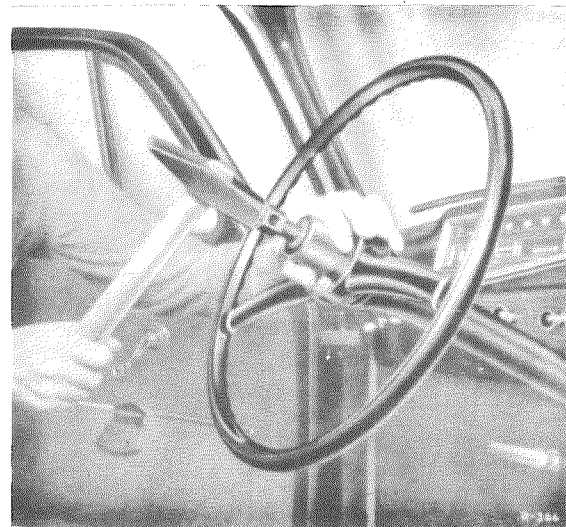

Fig. 46—2/3

- Remove the puller. Then remove the hexagon nut altogether and take off the steering wheel.

Installation:

- Place the steering wheel in position; do not omit the key when doing this.
- Screw on the hexagon nut with a new locking plate and tighten to a torque of 3 mkg.
- Connect up the wiring harness to the contact plate (see Fig. 46—2/4). When connecting up the individual cables, pay attention to the color coding. The connecting terminals on the contact plate are marked with colored dots.

Connect as follows:

The black/yellow cable (Lead No. 2) to the terminal (1) marked with a brown dot,

the black/green cable (Lead No. 4) to the terminal (3) marked with a black dot and a green dot,

the black/white cable (Lead No. 3) to the terminal (3) marked with a black dot and a white dot,

the brown cable (Lead No. 5) to the terminal (4) marked with a brown dot,

the black/white/green cable (Lead No. 1) to terminal (5) marked with a black dot, a white

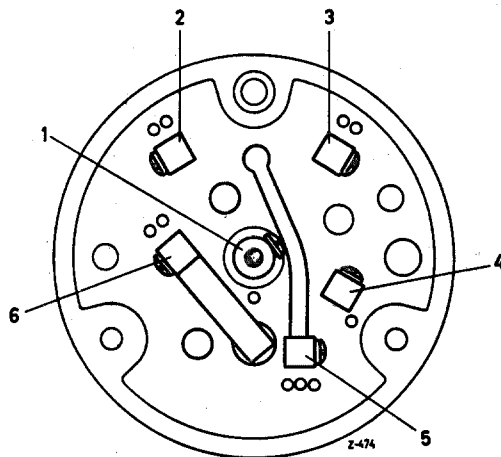

Fig. 46 — 2/4

- 1 Terminal contact bolt
- 2 Connecting terminal for right flash direction signal
- 3 Connecting terminal for left flash direction signal
- 4 Connecting terminal for horn ring ground
- 5 Connecting terminal for flash direction signal switch
- 6 Remains free

dot and a green dot (see Job No. 54—3, Section A, Diagram of the Wiring Harness for the Steering Tube).

Note: The terminal (6) marked with a brown dot and a red dot, must be left free.

- Install the contact plate so that the bore in the contact plate is in line with the one in the steering column jacket (see Fig. 46—1/3). Then fix the contact plate to the steering wheel, using the three fixing screws (1) (see Fig. 46—2/2).
- Insert the brass washer (61) in the steering wheel and install the horn ring (58); when doing this, lift the notch plate (59) a little. Then install the contact cup (63), insulating plate (64), compression spring (65) and contact disk (62), and screw on the adjusting nut (66) (Fig. 46—2/5).

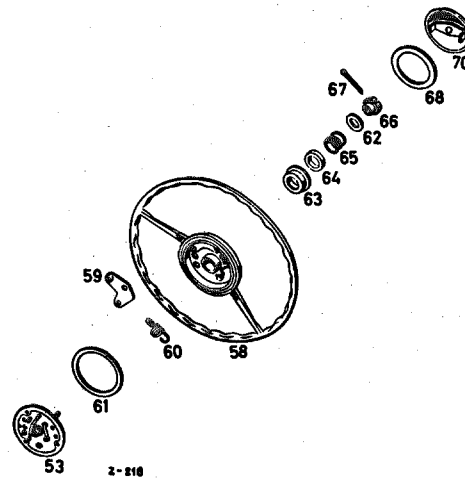

Fig. 46 — 2/5

- 53 Contact plate
- 58 Horn ring
- 59 Notch plate
- 60 Return spring
- 61 Washer
- 62 Contact disk
- 63 Contact cup
- 64 Insulating plate
- 65 Compression spring
- 66 Adjusting nut
- 67 Cotter pin 1 × 18 DIN 94
- 68 Rubber washer
- 70 Trademark plate

- Install the adjusting nut (66) so that the contact travel is neither too large nor too small. Operate the horn to check the contact. Then lock the nut with the cotter pin.
- Check that the flash direction signals are working properly.
- Install the rubber washer (68) and press on the cap with the trademark plate (70) (see Fig. 46—2/5).