

# Removal and Installation of Engine together with Transmission

Job-No.

01 — 1

## Removal:

1. Remove hood (see Job No. 88 — 6).

**Caution:** In order to avoid possible damage to enamel on the fenders, the hood must not be forced too far back when opening.

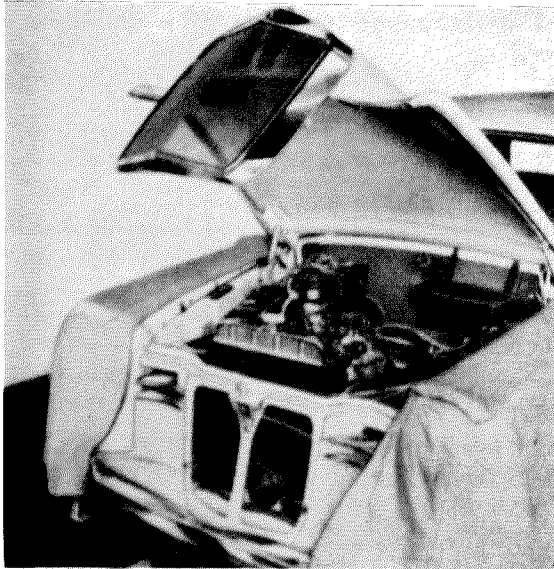

Fig. 01 — 1/1

2. Drain cooling water and remove radiator (see Job No. 50 — 1). Disconnect heat exchanger hoses and radiator thermometer hoses.
3. Unscrew air intake silencer with bracket.
4. Disconnect the ground cable from the negative terminal of the battery.
5. Unscrew and raise slightly the left section (3) of the engine compartment panel. Then release the center section (2), pull it out of the groove and press it back approximately 4 centimeters (see Fig. 01 — 1/2).
6. Disconnect the ground cable at the upper screw on starter by unscrewing the hexagon nut.

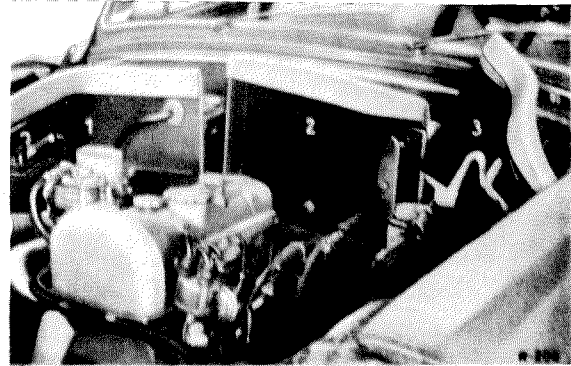

Fig. 01 — 1/2

- 1 Right engine compartment panel
- 2 Center engine compartment panel
- 3 Left engine compartment panel

Disconnect all electric cables at the generator, starter and distributor.

7. Disconnect the ignition adjustment control cable at the bearing support of the distributor and also the choke cable at the carburetor. Detach the accelerator linkage at the control shaft lever.

**Note:** Recently the ignition adjustment control cable has been superseded.

8. Disconnect the fuel line at the fuel pump and the flexible hose for the oil pressure gage line at the oil filter.

**Note:** In order to avoid damage to the fuel pump and the carburetor when detaching or attaching the fuel line, the threaded union must always be held steady with a second wrench.

9. Remove the spring clips from the ball-cup connectors (7) and (8) and then detach the ball-cup connectors at the bearing (see Fig. 01 — 1/3).

10. Detach exhaust from exhaust manifold.

11. Detach the exhaust suspension support (2) at the mounting plate (1) on the transmission, and press the support (2) slightly outward together with the exhaust pipe (see Fig. 01 — 1/4).

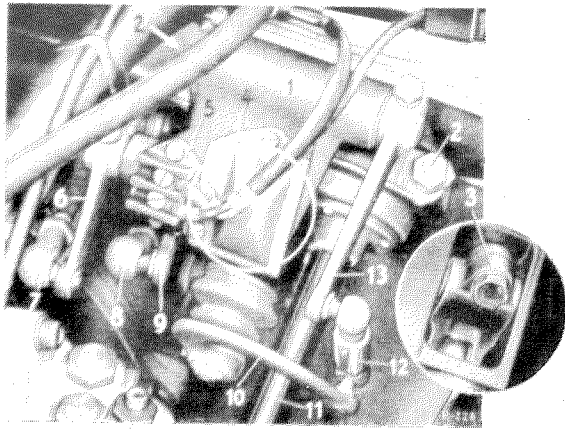

Fig. 01 — 1/3

- |                                      |                                     |
|--------------------------------------|-------------------------------------|
| 1 Bearing                            | 8 Shift rod ball-cup connector      |
| 2 Hexagon screw                      | 9 Relay shaft lever                 |
| 3 Selector lever at shift tube       | 10 Lever at shift tube              |
| 4 Dust cover                         | 11 Steering tube                    |
| 5 Cable connector                    | 12 Spring-loaded ball-cup connector |
| 6 Selector lever                     | 13 Relay lever                      |
| 7 Ball-cup connector at selector rod |                                     |

12. Disconnect the flexible speedometer drive at the transmission.

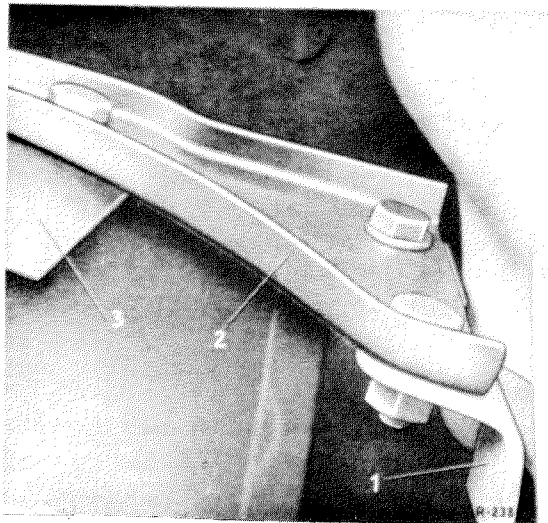

Fig. 01 — 1/4

- |                              |
|------------------------------|
| 1 Mounting plate             |
| 2 Support                    |
| 3 Front exhaust pipe bracket |

13. Detach the cover plate for propeller shaft intermediate bearing. Mark the position of the bearing bracket on the chassis base panel (5).

Then unscrew the two fixing screws (4) and washers (see Fig. 01 — 1/5).

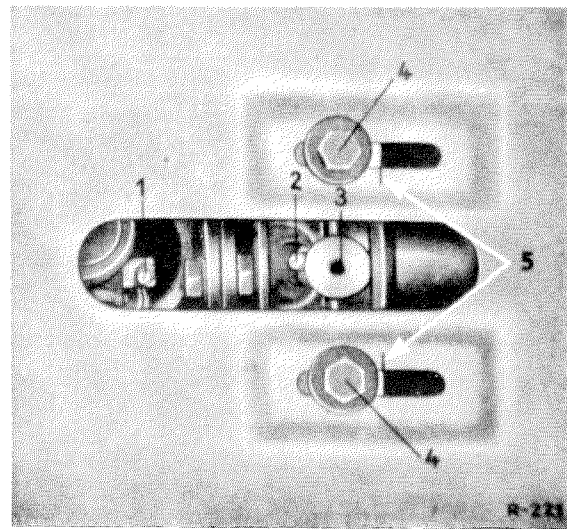

Fig. 01 — 1/5

- |  |
|--|
| 1 Front universal joint pinion rim grease fitting            |
| 2 Pinion rim grease fitting for annular grooved ball bearing |
| 3 Threaded bore for cover plate fixing screw                 |
| 4 Fixing screw for bearing bracket                           |
| 5 Position marking of bearing bracket on chassis base panel  |

14. Disconnect propeller shaft and shaft plate at the transmission and push backward.

**Note:** It is advisable to unscrew the pinion rim grease fitting at the rear end of the slip coupling, in order that the air can escape and the coupling can be easily telescoped.

Where later models are already provided with a bore in the sealing plate to allow superfluous air or grease to escape, the grease fitting need not be detached (see Job No. 41—1, Fig. 41—1/7).

15. Detach the return spring at the clutch throw-out fork and at the transmission. Then after loosening the adjusting screw (1) press down the turnbuckle and the pull rod. Release the swivel support (10) by removing the two hexagon screws from the spring plate (see Fig. 01 — 1/6).

16. Pass a suitable lifting cable around the left of the engine **in front of** the first bracket of the ignition lead conduit and tighten gently until it takes the weight (see Fig. 01 — 1/8).

17. Remove the self-locking nuts (7) of the rear engine mounting at the left and the right on the front axle support and remove the bolts (4) (see Fig. 01 — 1/7).

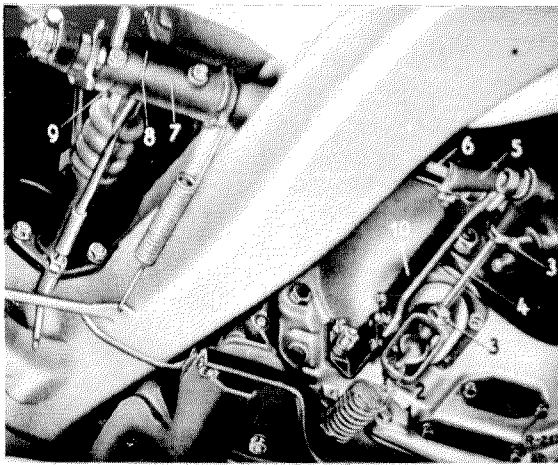

Fig. 01 — 1/6

- 1 Adjusting screw for free play of clutch pedal
- 2 Lock nut for adjusting screw
- 3 Lock nut for pull rod
- 4 Pull rod
- 5 Relay lever
- 6 Clutch pedal shaft
- 7 Brake pedal
- 8 Lock washer
- 9 Clutch pedal
- 10 Swivel support

18. Remove the left and right front engine mounting bolts; in doing so, hold the rubber mounting steady with Wrench SW 22 (see Fig. 01 — 1/9).

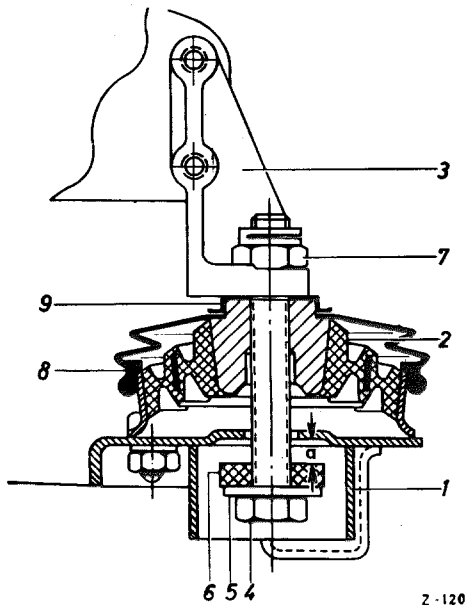

Fig. 01 — 1/7

Rear engine mounting

- 1 Front axle support
- 2 Rubber mounting
- 3 Rear engine support
- 4 Fixing screw
- 5 Washer
- 6 Rubber spacer 7 mm
- 7 Hexagon nut (self-locking)
- 8 Bellows
- 9 Metal cover
- a = 5 mm

19. In order to avoid damage, cover the right scoop of the conditioned air system with a piece of metal.

Then slightly raise the engine together with the transmission with the hoisting rig and tilt it to an angle of approximately 45°. Turn the front end of the engine slightly to the right, and the rear at the transmission to the left. In this position lift out the engine together with the transmission (see Fig. 01 — 1/8).

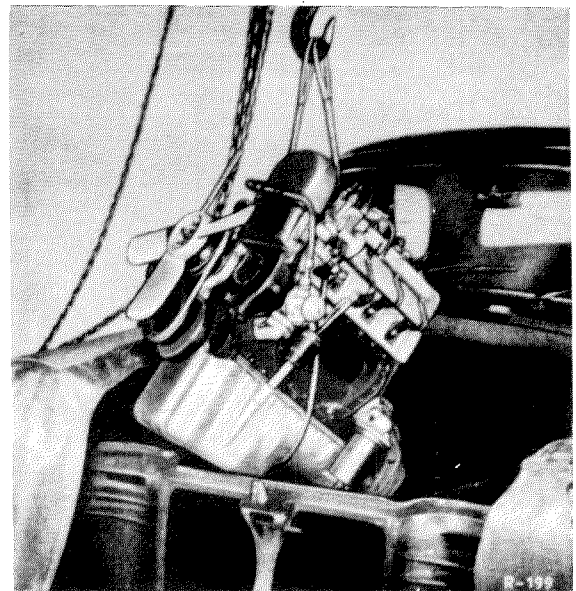

Fig. 01 — 1/8

Installation:

20. Hoist the engine together with transmission and lower it at an angle of approximately 45° (transmission downward) until the transmission is in the front part of the transmission channel. Now turn the front end of the engine slightly to the right and the rear end at the transmission slightly to the left and continue to lower it until the engine has passed the front cowling panel (see Fig. 01 — 1/8). Then turn the engine back into position, lower it and allow it to settle onto the front axle support.

**Note:** The front and rear engine mounting bolts can be placed in position with far greater ease if, after lowering the engine, the lifting cable is adjusted behind the first bracket of the ignition lead conduit so that the engine and the transmission are suspended in an approximately horizontal position.

21. Drop into position the fixing screws (1) for the front engine mounting at the left and right on the front axle support and screw in by hand (see Fig. 01 — 1/9). Do not forget the lock washers.

**Note:** The rubber mountings of the front and rear engine suspension are marked with a directional arrow and the inscription "vorn" "front" (see Job No. 22 — 1).

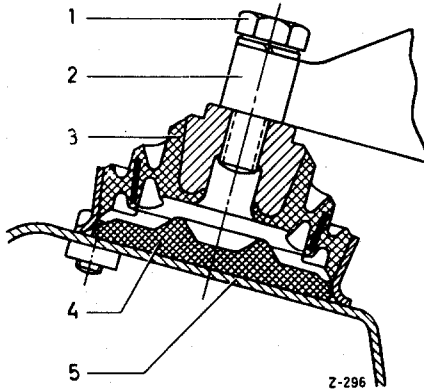

Fig. 01 — 1/9

Front engine suspension

- |                        |                             |
|------------------------|-----------------------------|
| 1 Hexagon screw        | 4 Buffer plate 121 223 0065 |
| 2 Front engine support | 5 Front axle support        |
| 3 Rubber mounting      |                             |

22. Press the rubber spacer (6) over the hexagon screw (4) with the welded washer. Screw the hexagon screw (4) approximately 2—3 turns into the rubber mounting (2) (see Fig. 01 — 1/10).

**Note:** To facilitate the positioning of the bolts the engine should be eased upward where necessary. Make sure that the bellows (8) and the metal cover (9) are correctly seated.

23. Remove the lifting cable and screw in the fixing screw (4) until the rubber spacer (6) just rests against the front axle support (see Fig. 01 — 1/10).

24. Measure the distance from the front axle support to the head of the hexagon screw (4) with a depth gage. Then unscrew the hexagon screw a distance of 5 mm. Using the depth gage as a check, measure the distance again. It should now register 5 mm less.

**Note:** It is necessary to screw the hexagon screw into position in this manner in order to limit the upward movement of the rear engine mounting to  $a = 5$  mm.

If a depth gage is not available, the screw should be unscrewed  $2\frac{1}{2}$  turns after the rubber spacer is in position. (Pitch of the thread 2 mm).

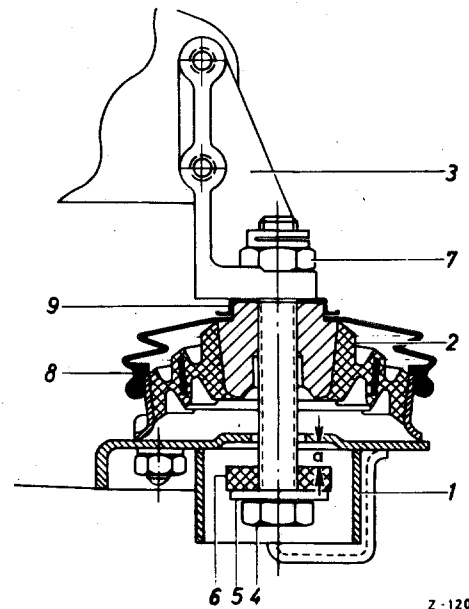

Fig. 01 — 1/10

Rear engine suspension

- |                       |                              |
|-----------------------|------------------------------|
| 1 Front axle support  | 6 Rubber spacer 7 mm         |
| 2 Rubber mounting     | 7 Hexagon nut (self-locking) |
| 3 Rear engine support | 8 Bellows                    |
| 4 Hexagon screw       | 9 Metal cover                |
| 5 Washer              | a 5 mm                       |

25. Screw the nut (7) onto the hexagon screw (4) and tighten. Also tighten the hexagon screw of the front engine suspension.

26. Press forward the propeller shaft, connect at the transmission and cotter the castle nuts.

**Note:** Do not omit the sealing ring (3) between center cross and the propeller-shaft flange (Fig. 01 — 1/11).

Check that the shaft plate is correctly positioned (see Job. No. 41—1).

27. Attach the propeller-shaft intermediate bearing without forcing, noting the position marked during the removal operation (see Fig. 01 — 1/5).

28. Fit to spring plate (11) the two hexagon screws which hold the swivel support (12) for the clutch actuating mechanism (see Fig. 01 — 1/12).

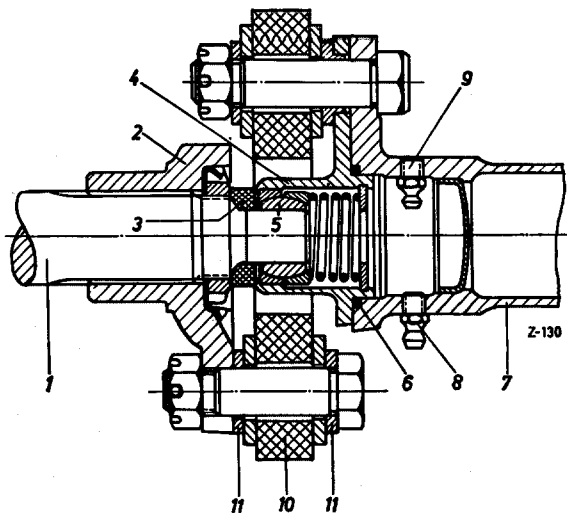

Fig. 01 — 1/11

- |                                     |                             |
|-------------------------------------|-----------------------------|
| 1 Transmission mainshaft            | 6 Sealing ring              |
| 2 Three-way flange on the mainshaft | 7 Propeller shaft           |
| 3 Bracket                           | 8 Pinion rim grease fitting |
| 4 Center cross                      | 9 Relief grease fitting     |
| 5 Locating ball                     | 10 Shaft plate              |
|                                     | 11 Washer 187 990 14 40     |

29. Then center the pedal shaft in the bore of the chassis base plate.

**Horizontal centering of the Pedal shaft** is carried out by removing or adding shims at the point on the clutch housing where the swivel support is mounted (see Fig. 01 — 1/12).

**The vertical centering of the pedal shaft** is carried out by moving the bracket (3) upward or downward (see Fig. 01 — 1/12).

**Note:** At present, modified brackets are being fitted. Instead of the two slot holes, these brackets are provided with two normal bores. The shim (4) is no longer necessary. In order to facilitate the vertical adjustment of the clutch pedal shaft the two bores in the swivel support have been increased in size from 6.4 mm  $\varnothing$  to 7.0 mm  $\varnothing$ .

If a new bracket is fitted at a later date, the two holes of the swivel support should be bored out to 7 mm  $\varnothing$ .

30. Attach the turnbuckle for the clutch actuating mechanism and the return spring for the clutch throw-out fork.
31. Adjust the clutch pedal free play to 25 mm. Check the clutch pedal for ease of movement (see Job No. 29 — 3).

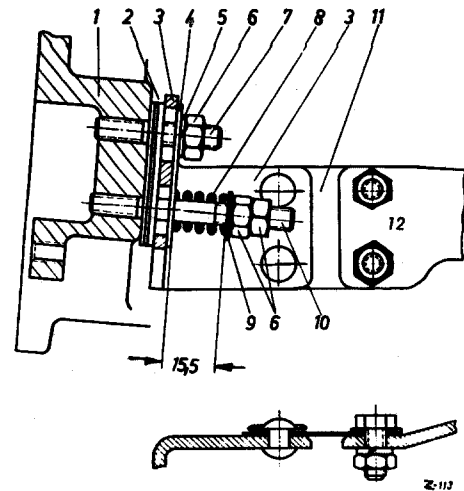

Fig. 01 — 1/12

- |                  |                    |
|------------------|--------------------|
| 1 Clutch housing | 7 Stud bolt        |
| 2 Shims          | 8 Damper spring    |
| 3 Bracket        | 9 Washer           |
| 4 Shim           | 10 Stud bolt       |
| 5 Lock washer    | 11 Spring retainer |
| 6 Hexagon nut    | 12 Swivel support  |

32. Attach the ball-cup connectors (7) and (8) of the selector and shift rod (see Fig. 01 — 1/3). Then fasten the clamps to the ball-cup connectors.

33. Check the adjustment of the gearshift (see Job No. 26 — 3).

34. Connect all electric cables. When connecting the electric cables pay attention to the color coding.

a) Cable connections to Generator:

Connect the black cable of the regulator harness (1.5 mm<sup>2</sup> section) fitted with tag to terminal DF

the red cable (4 mm<sup>2</sup> section) to terminal D + (61)

the brown cable (2.5 mm<sup>2</sup> section) to terminal D — of the generator (see also Job No. 54 — 4, section A).

**Note: Be sure to connect cables to correct terminals! Incorrect connection of the terminals involves the danger of pole reversal to the generator and could result in the destruction of the regulator!**

b) Cable Connections to Starter:

Connect battery cable 30 and the red cable 51 (red lead No. 53 and No. 54 of the main wiring harness see Job No. 54 — 1, Section A, Circuit Diagram of Main Wiring), cable

Sheaf to the terminal of the solenoid switch. Push the rubber cap over the terminal.

Connect the black/red control cable (lead No. 25) to the slotted screw at the solenoid switch.

**Note:** The black/red control cable must not be passed through the rubber grommet at the starter terminal, since it might rub against the battery cable terminal 30 and 51 (see Job No. 15—1, Fig. 15—1/2). In this case the control cable might become live and operate the starter. The black/red cable must therefore be wound around cable 30 and 51 and connected directly to terminal 50.

- c) Fasten the ground strap to the upper fixing screw on starter.
  - d) Connect cable from the ignition coil, terminal 1, to the distributor.
  - e) Connect the reversing light harness to the connector (5) for the reversing light (see Fig. 01—1/3).
  - f) Connect the ground cable to the negative terminal of the battery.
35. Attach the exhaust pipe with a new gasket to the exhaust manifold; tighten the three hexagon screws and nuts evenly.
  36. Attach the support (22) of the exhaust suspension to the mounting plate (33) with the rubber washers (22a), the cup washers (22b), the sleeves (22c) and the two hexagon screws (23a) with the washers (24a), spring washers (25), and hexagon nuts (26) (Fig. 01—1/3).
  37. Connect the flexible speedometer drive.
  38. Connect the choke control cable at the carburetor (see Job No. 30—6, paragraphs 15—20).
  39. Connect the ignition adjustment control cable at the distributor bearing support or

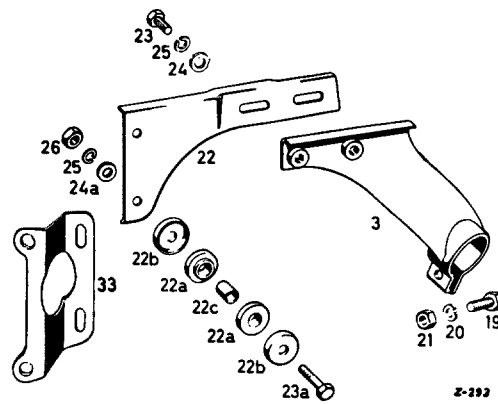

Fig. 01—1/13

3 Bracket	23 Hexagon screw M 8x20
19 Hexagon Screw M 8x20	23a Hexagon screw M.8x40
20 Spring washer	24 Washer
21 Hexagon nut	24a Washer
22 Support	25 Spring washer
22a Rubber washer	26 Hexagon nut
22b Cup washer	33 Mounting plate
22c Sleeve	

at the adjusting lever (see Job No. 30—8, paragraphs 11—13).

**Note:** This operation has become unnecessary on recent models, because the ignition adjustment control cable has been superseded.

40. Install the left and center engine compartment panels.
41. Install the radiator (see Job No. 50—1) and connect up the radiator thermometer.
42. Fit the air intake silencer.
43. Connect the fuel lines and the flexible hose of the oil gage line at the oil filter.
44. Install the engine hood (see Job No. 88—6). Check the engine hood for correct seating.
45. Fill up with cooling water and bleed the heat exchanger.
46. Check the oil level in the engine, if necessary top up with oil.
47. Start engine and check all unions for mechanical tightness and leakage and check the electrical system.
48. Check the cooling-water level, and if necessary top up with water.

### Shorter rear engine support

When harder rubber mountings are installed (see Job No. 24 — 1, Fig. 5, Note) for the rear engine suspension, the engine will be too high at the rear if the engine support (3) which was standard up to now is used (Fig. 01—1/14). To correct this, an engine support which is 5 mm shorter is at present being used

as per Part No. 121 233 29 04 at the left  
and Part No. 121 233 30 04 at the right.

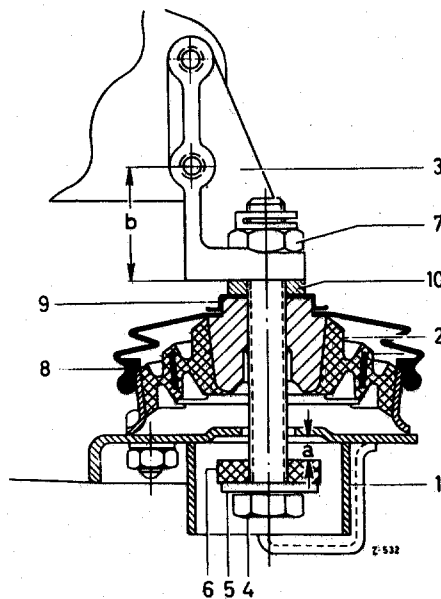

Fig. 01—1/14

- 1 Front axle support
  - 2 Rubber mounting
  - 3 Rear engine support
  - 4 Hexagon screw with washer (5)
  - 6 Rubber spacer 7 mm thick
  - 7 Hexagon nut (self-locking)
  - 8 Bellows
  - 9 Metal cover
  - 10 Washer 5 mm thick
- Part No. 186 990 16 40  
a = 5 mm

Previous version	b	42 mm
New version	b	37 mm

For reasons of standardization, these supports which are 5 mm shorter are now used (as of Engine No. 75 01 213) even with the normal standard version of the rubber mounting. To compensate for the difference in height, a washer 5 mm thick (10), (Part No. 186 990 16 40), is inserted between the engine support (3) and the metal cover (9) and a longer hexagon screw (4) (Part No. 121 220 0171 M 12×100) is used.

**When installing the engine make sure that the washer (10) is not omitted when using standard rubber mountings. When using harder rubber mountings the washer must not be fitted.**