

Preface

The present

Workshop Manual

OM Diesel Engines

Untertuerkheim Manufacture

gives detailed and thorough references on the Models OM 636 and OM 621; it is intended also for workshops – especially outside Germany – with as yet little experience in the field of passenger car Diesel engines and should help to ensure proper adjustments and expert repairs. A detailed description of the injection system has, therefore, been included herein to guarantee a better understanding of the Diesel engine.

Besides the vehicle engines, this book also includes all versions of the built-in engines. The tables from page 00-1/11 to 00-1/31 specify all the deviations from the individual versions with respect to the basic engine.

Further supplementary sheets will keep this workshop manual up to date, so that you are informed of all modifications as far as they are of importance for your practical work.

Daimler-Benz Aktiengesellschaft

Export Service

Stuttgart-Untertuerkheim, December 1959

Numbering System of Workshop Manuals

Important:

When leafing through this Workshop Manual you will immediately notice that the pages are not numbered consecutively. This does not mean that the Workshop Manual which you now call your own is incomplete. On the contrary, the manual is purposely composed of Groups. These Groups in turn are divided into Job Nos. which are then numbered consecutively. The Group code as used in this manual corresponds to the Group Nos. of the Spare Parts Lists.

This numbering system together with the looseleaf binder facilitates a constant supplementing of the Workshop Manual without interrupting the numbering sequence.

An example will serve to illustrate the above:

Page 07-04/19

is the nineteenth page of the

Job No. 07-04 – Design and Operation of the Fuel System
which is part of Group 07, Fuel Injection System.

Job No. 07-04 presently has 23 pages. Should at a later date an addition to this Job No. become necessary, these pages would be numbered 07-4/24, 07-4/25, etc.

In case of modifications any one of the pages can be replaced by a page of the same No. These altered pages are then identified by a notation, i.e. "Modification No. 1a".

Corrections and Supplements for Workshop Manual OM Diesel Engines Untertürkheim Production

Please enter the corrections and supplements – printed in italics – in your Workshop Manual OM Diesel Engines.

Page

- 34 line 2, add: *and 180 Db*
- 0–1/2 between 3rd and 4th line of left column, add:
Glow plug thermal output 50 watts
- above the line "Total weight of engine", add:
Min. fuel consumption 200 g/HPH at 2000 rpm
- underneath line "Generator optional", add:
voltage control
- underneath line "(also see page 15–11/3)", add:
Begin of charging at 785 rpm of crankshaft
Transmission ratio crankshaft/generator i = 1:1.72
- underneath line "Starter", add:
(screw push starter)
and underneath:
Transmission ratio drive pinion/flywheel i = 1:10.2
- 00–1 In the Table "Tightening Torques" in the fourth line
"Cylinder head bolts with cold engine and with warm engine"
in column OM 621 "8 mkg" should be *9 mkg*
- 00–8/1 In third paragraph add to last sentence:
(also see Job No. 05–20)
- 00–13/2 In section "B. OM 621" line 1, change to:
model 190 D; 190 Db and 190 Dc
- 00–13/2 in item 4, line 6 add before parenthesis:
... there should be at least approx. 2 mm clearance
- After item 4 add the following note:
Note: After setting push-pull switch check for easy operation at oblong hole on adjusting lever of injection pump. Also check whether adjusting lever is actually set to full load.
- 01–0/1 Under model OM 621, line 10, 23.1–24.3 should be: *23.5–25.5*
- 01–0/2
- 01–0/5 In the Table "Cylinder Crankcase-Cylinder Liners for model OM 636" the fifth line should be:
- | | | |
|---|-----------------------|------------------|
| <i>Overlap between cylinder bore and cylinder liner</i> | <i>without collar</i> | <i>0.07–0.09</i> |
| | <i>with collar</i> | <i>0.04–0.07</i> |
- 01–1/2 item 8, line 3 should be:
special wrench part No. 63658901 63 and socket 63658901 07 or 63658902 07
- 01–5/1 in right-hand column, next to last paragraph, add to last bold line:
(see Job No. 01–0 and Fig. 01–6/6)
- 01–5/2 under legend of Fig. 01–5/4 add under OM 621:
190 D, 190 Db, type designation 621.910
- 01–7/1 the first line should be:
The cylinder heads of models 190 D and 190 Db leave the factory ...
- Between 2nd and 3d sentence add:
Cylinder heads of models 180 Dc, 190 Dc, and L and 0 319 D with OM 621 engine leave the factory with both intake and exhaust valve seat rings
- in right-hand column after Fig. 01–7/2 the 2nd and 3d line should be:
... specified overlap; if this overlap ...
- 01–15/4 in item 20, second paragraph of note, 5th line, change to:
the length of the driving shaft 64.2 mm; the hub length of the pump drive wheel 21.5 mm. In ...

after the 3rd paragraph add the following:
As of late a pump drive wheel part No. 6360770712 at a hub length of 25.5 mm is installed. The above named compensating ring need not be installed in this drive wheel.

In item 26 add to last line:
The pump drive wheel is available in sizes 0—+ 18/100 mm.

03-2 in item 2 add behind note:
The counterweight (11) for engines of type designations 621.910 and 621.914 is 22.5 mm thick, for type designations 621.912 and 621.913 32.5 mm.

under item 3, add:
Note: Pulley (9) of engine type designation 621.910 and 914 has a diameter of 138 mm, that of type designation 621.912 and 621.913 a dia. of 125 mm.

03-6/1 Between the 1st and 2nd sentence of the first line add the following sentence:
Crankshafts of type designations 621.912, 913 and 914 differ from crankshaft of type designation 621.910 by a larger counterweight on center pin.

03-15/1 Strike out bold line "The piston play is 0.06 for Mahle and Nüral pistons". The last line underneath "the running clearance of 0.06 mm is ensured" must be changed to:
... the specified running play (piston play) is maintained (for piston play refer to page 03-0/4).

03-15/2 the last line of the bold paragraph should be:
oil slot bevel ring instead of hose-shaped expander ring.

The same applies to the 6th line of the right-hand column.

03-16/3 item 3 as from 5th line should be:
... without locking plate with the specified torque (see Fig. 03-7/2 and Job No. 00-1).

05-01 in the table "valve Springs" for model OM 621 behind "inner spring only for intake valve", add:
models 190 D and 190 Db type designation 621.910

05-2/1 in the 2nd line of the right-hand column change smaller to *larger* than 17.02; the 12th line should be:
Bore bush to 17.00 prior to pressing-in, then ream to specified dimension of 17.00-17-018 mm.
Strike out ... "or bore"

05-2/2 the next-to-last and last line prior to Fig. 05-2/4 should be:
... the rocker brackets of earlier production require assembly acc. to Fig. 05-2/3 in case of repairs.

05-28/1 under item 6 add the following note:
Note: Prior to pressing out the intermediate gear shaft the chain box underneath the intermediate gear should be stuffed with a clean rag to prevent the thrust ring from falling into crankcase

07/2 Add the following new Job No. to Alphabetical Index:
07-10 Replace seal between pipe connection and pressure valve holder page 07-10/1

07-0/1 in the Table "Injection Nozzles" add in the next-to-last line after Injection Lines Job No. 07-16

Also add under this table:
OM 636 and OM 621 Nozzle Holder Bodies (without nozzle)
Bosch designation KCA 30 SD 2/4
DB Part No. 000017 31 31

07-25/4 In the note of item 12 strike out the last 3 lines. Instead add:
Attention please! During an overhaul or with the injection timer removed, install a bushing (3) without notched pin with thrust ring (24), if not yet there.

09-3/4 Add following sentence to 12th line:
In addition, a silencer Part No. 1890700568 against fuel noise can be installed in fuel return line (see Job No. 00-9)

09-3/5 After the last line add the following paragraph:
When noises are heard in the lines a silencer Part No. 1890700568 can be installed in the fuel return line between injection pump or overflow valve and the fuel main filter or crosspiece (see Job No. 00-9)

15-00/2 Add after line 6:
Bosch, type EJD 1.8/12 R 104
Bosch, type EJD 1.8/24 R

In the 7th line 12 Volt should be "12 or 24 volt"

15-00/3 The legend under Fig. 15-00/2 should be:
Generator LJ/GEH 90/12-2300 R 15
(dustproof)

- 15-1/3 Supplement Table "Starters" as follows:
0001518601 621.910, 913, 914
EJD 1.8/12 R 88
0011511301 621.912
EJD 1.8/12 R 104
- 15-16/1 Legend of Fig. 15-16/1 should be:
Generator LJ/GEG 160/12-2500 R 8, R 9 and R 10
- 15-30/1 Behind the line "Type designations of the different glow plug versions" add the following:
(refer to Job No. 15-00, section E)
Strike out all other lines underneath.
- 18-1/4 In the bold line 0.3 should be *0.5 atü*
- 20-5/3 Under item 9 add the following note:
Note: To prevent scuffing of a twisted cooling water hose against the set bolt holding the chain tightener cooling water hose 6212030082 and thermostat housing 1802030173 are now carrying a mark for accurate aligning. The mark on the cooling water hose is a painted on white arrow and on the thermostat housing a cast on 15 mm long elevation.
- 20-8/1 In the first line "five" water pump versions should be *six*
Following item e) item f) should be added:
f) Water pump with self lubricating ball bearing without pulley Part No. 6362001901
- 20-8/6 The bold line should end:
b), c) and f)
- 20-8/8 Item 15 should be followed by the following note:
Note: Water pumps 6362001901 with self-lubricating ball bearings (Fatnir bearings) should be given a coat of "silicon grease grade 300 heavy" supplied by Wacker-Chemie on both sides of the ball bearings prior to installing bearings (6) and (9) (Fig. 20-8/8). In addition there should be an overlap of 0.003-0.007 mm between water pump shaft and ball bearing.

Group Index

General	0
Tightening Torques, Testing and Adjusting Work on the Engine, as well as Disassembly and Assembly of Engine	00
Cylinder Head, Cylinder Crankcase, Timing Gear Housing Cover, Operation Hour Counter and Revolution Counter – Drive	01
Crank Assembly	03
Timing	05
Injection System	07
Fuel Filter and Air Filter	09
Intake Manifold and Exhaust Manifold	14
Electrical Equipment of Engine	15
Engine Lubrication	18
Engine Cooling	20

rocker arms	05-0/2, 05-0/3
valve stems (exhaust and intake)	05-0/1
Commutator of generator, checking and repairing	15-13/1
Commutator of starter, checking and repairing	15-4/2
Compression pressure measuring values	00-5/1 00-0/1
Compression ratio of engine	0-1/1, 0-2/1
Connecting rod general data, measures and tolerances	03-0/2
removal and installation	03-11/1
repairing and re-bedding	03-13/1
squaring	03-13/5
Connecting rod bolts, tightening	03-13/4, 00-1/1
Continuous output A	0-1/4
Continuous output B	0-1/4
Control rod travel checking values incl. adaptation	07-8/2 07-8/3
Conversion tables	17
Cooling system capacity cleaning	0-1/11 0-6/2
Cooling water additives circuit operating temperature thermostat treating agents	0-6/1 20-1/1 0-1/2, 0-2/1 20-1/1, 20-0/1 0-6/1
Counterweight, removal and installation	03-2
Crankshaft annular grooved bearing, removal and installation axial clearance balancing grinding general data, measures and tolerances radial clearance re-bedding removal and installation seal ring, front seal ring, rear (fabric ring)	03-17 03-9/1 03-7/1 03-6/1 03-0/1 03-9/1 03-9/1 03-5/1 03-3/1 03-5/4, 03-5/7
Crankshaft gear position to camshaft gear removal and installation	00-7/1 03-5/1
Cross section of engine	36
Cylinder bore boring and honing repair sizes	01-27/1 01-0/5
Cylinder crankcase cleaning, pressure-testing and grinding disassembly and assembly	01-26/1 01-25/1
Cylinder head general data, measures and tolerances grinding and pressure-testing removal and installation re-tightening cylinder head bolts tightening torque of cyl. head bolts	01-0/1 01-5/1 01-3/1 01-3/5, 01-3/10 01-3/4, 01-3/9
Cylinder head covers, list	01-3/5
Cylinder liners, installing	01-29/1
D efurring of the cooling system	0-6/2
Degreasing of the cooling system	0-6/2

Design and operation of centrifugal governor	07-4/11
fuel feed pump	07-4/17
injection nozzle	07-4/16
injection pump	07-4/1
injection system	07-4/1
injection timing device	07-4/15
pneumatic governor	07-4/4
Deviations of the individual engines with respect to the standard engine	0-1/11
Diaphragms and governor springs, list	07-0/2
Diaphragm assembly, description	07-4/4, 07-4/22
Dimensions of governor springs	07-0/3
Distance between burner surface and separating surface of cylinder head cylinder crankcase upper surface and piston head in TDC cylinder head separating surface and valves fan and radiator core piston head and piston hd. recess piston hd. recess and front surface of pre-chamber	03-0/5 03-0/5 01-0/2 20-0/1, 20-5/3 03-0/5 03-0/5
Drive for inj. pump and oil pump general data, measures and tolerances	05-0/5
Drive for revolution counter	01-12/1
Drive shaft of injection pump removal and installation	07-27/1
E lectrical system description wiring diagram	15-00/1 15-00/1
E ngine becomes too hot capacities continuous output A continuous output B cooling cross section disassembly and assembly does not reach full power does not start fails to stop when switched off idling speed, adjusting knocks knocks heavily longitudinal and cross section lubrication lubrication points maintenance model plate no-load maximum speed, adjusting oil circuit oil consumption too high oil loss oil pressure too low oils outputs runs backwards runs irregularly smokes heavily speed ranges speed too high	0-10/5 0-1/11, 0-2/2 0-1/6 0-1/7 20-1/1 36 00-20/1 0-10/3 0-10/1 0-10/5 00-11/1 0-10/5 0-10/4 36 18-1/1 0-9/2 0-9/1 21 00-12/1 18-1/1 0-10/6 0-10/6 0-10/6, 18-1/4 0-4 0-1/11 0-10/2 0-10/3 0-10/4 07-4/10 0-10/5

types	0-1/11, 0-2/1
view	27
Equipment of the standard engine	0-1/11
Exhaust gases, observation of	00-4/1
Exhaust manifold	
checking and repairing	14-8/2
removal and installation	14-5/1
table	14-8/1
Exhaust pipe	0-1/3
Exhaust shading number	07-8/5
Fabric seal ring halves for rear	
crankshaft sealing, removal	
and inst.	03-5/4, 03-5/7
Fabricating of injection lines	07-16/1
Faltering of engine when idling	07-8/5
Fan	
distance to radiator core	20-0/1, 20-5/3
mounting	20-12/1
table	20-12/4
Fan bracket	
disassembly and assembly	20-15/2
removal and installation	20-15/1
Feed begin	00-0/1
Feed begin, adjusting of	00-6/1
acc. to overflow method	00-6/5
with stroke advance device	00-6/10
Feed pressure of fuel feed pump	00-0/1
Feed pump designation and its	
characteristic features	07-14/2
Feed quantity check with installed	
injection pump	07-8/2
Flange nipple	07-23/2
Flywheel	
clutch surface, re-machining	03-19
general data, measures and tolerances	03-0/6
re-balancing	03-8/1
removal and installation	03-16/1
ring gear, replacement	03-18/1
table	03-16/2
Forced circulation cooling	20-3/1
Fuel consumption	0-1/9, 0-2/2
Fuel feed pump	
checking	00-9/1
description	07-4/17
removal and installation	07-13/1
table	07-14/2
testing and partial repair	07-14/1
Fuel hoses, removal and installation	07-15/1
Fuel injection system	07-3/1
Fuel main filter	
cleaning and checking	09-3/1
removal and installation	09-1/1
Fuel pre-filter, cleaning of	09-5/1
Fuel system, bleeding of	00-10/1
Fuels and additives	0-5/1
Full-load injection quantity	0-1/11
Full-load maximum speed	07-4/10, 0-1/11
Full-load stop, adjusting of	07-8/2
General data, measures and tolerances of	
battery	15-0/3
camshaft and camshaft bearings	05-0/6

chain tightener	05-0/3
connecting rods	03-0/2
crankshaft	03-0/1
cylinder bores	01-0/5
cylinder crankcase	01-0/4
cylinder head	01-0/1
cylinder liners	01-0/5
drive for injection pump and oil pump	05-0/5
engine cooling	20-0/1
flywheel	03-0/6
generator	15-0/2
guide sprocket	05-0/4
idler sprocket and support	05-0/4
injection lines	07-0/1
injection nozzles	07-0/1
injection pump	07-0/2
injection timing device	07-0/4
oil pressure relief valve in gallery	18-0/2
oil pressure relief valve in oil filter	18-0/2
oil pump	18-0/1
oil pump drive shaft	18-0/2
pistons	03-0/3
radiator cap	20-0/1
regulator switch	15-0/2
rocker arms and rocker arm	
supports	05-0/2, 05-0/3
starter motor	15-0/1
thermostat	20-0/1
throttle duct	07-0/4
timing gears	05-0/5
valve guides	01-0/4
valve seat machining	01-0/2
valve seat rings	01-0/3
valve spring	05-0/1
valve tappets	01-0/6, 05-0/2
valves	05-0/1
Generator	
armature, checking for shorting to	
ground	15-5/1
armature checking for short in winding	15-5/1
carbon brushes	15-12/1
commutator	15-12/1
description	15-00/2
disassembly and assembly	15-13/1
electrical testing	15-16/1
exciter winding, checking	15-5/1
general data, measures and tolerances	15-0/2
maintenance hints	15-12/1
regulator switch	15-16/1
removal and installation	15-11/1
table	15-11/3
trouble shooting	15-17/1
voltage and current control, checking	15-16/2
Glowing system	
description	15-00/4
Glow plug	
checking	00-4/1, 15-32/1
description	15-30/1
designation	15-30/1
removal and installation	15-31/1
Glow plug control does not light up	0-10/1
Glow starter and stop switch	
description	15-33/1
wire cable, adjusting of	00-13/1
Governing begin	0-1/11
Governing end	0-1/11

Gradation on flywheel	00-6/4
pulley of crankshaft	00-6/3, 00-6/12
Grinding of camshaft	05-38/1
clutch surface of flywheel	03-19
crankshaft	03-6/1
valves	05-13/1
Guide rails, removal and installation	05-29
Guide sprocket	
general data, measures and tolerances	05-0/4
removal and installation	05-25/1
repairing	05-26

H ardness of	
big end bearing pins	03-0/1
camshaft bearing pin	05-0/6
camshaft, lobe of cam	05-0/6
crankshaft journal	03-0/1
Heat exchanger	20-3/1
Hints for tracing faults	0-10/1

I dler sprocket and support	
general data, measures and tolerances	05-0/4
removal and installation	05-23/1
repairing of	05-24/1

I dling speed	
adjusting	00-11/1
description	07-4/11
values	00-0/1

I njection lines	
checking, cleaning and manufacturing	07-16/1
general data, measures and tolerances	07-0/1
removal and installation	07-15/1

I njection nozzles	
checking	00-4/1
checking for leaks	07-18/5
description	07-4/16
designation	07-0/1
disassembly, cleaning and assembly	07-18/1
general data, measures and tolerances	07-0/1
removal and installation	07-17/1
spray pattern and buzzing test	07-18/5
spray pressure, adjusting of	07-18/5

I njection pump	
checking and adjusting when installed	07-8/1
description	07-4/1, 07-4/20
drive shaft, removal and installation	07-27/1
general data, measures and tolerances	07-0/2
model plate	21
operation in altitudes above 2000 m	
above sea level	07-2/9, 07-2/23
operation in altitudes up to 2000 m	
above sea level	07-2/2, 07-2/22
removal and installation	07-11/1
replacement pump for operation	
above 2000 m above sea level	07-2/21, 07-2/23
replacement pump for operation	
up to 2000 m above sea level	07-2/13, 07-2/23
table	07-2/1
testing and adjusting on test stand	07-5/1
I njection system	07-3/1

I njection system functioning	07-4/1
I njection timing device	
checking	07-28/1
description	07-4/15
disassembly and assembly	07-28/1
general data, measures and tolerances	07-0/4
removal and installation	07-25/1
I ntake line	
checking and repairing	14-5/1
removal and installation	14-1/1
table	14-3
I ntake silencer (air filter)	09-8/1
I ntermediate gear	
for injection pump drive	07-25/3, 07-27/3
I ntermediate plate or base plate between crankcase and timing housing cover	01-15/3

K nocking of the engine	0-10/4
K nocking noise	
in the engine	0-10/5
in the feed pump	0-10/5

L apped bearings of crankshaft	03-9/1
L ist of test sheets	
for injection pumps and governors	07-1/1
L ongitudinal section of engine	36
L ube oil consumption	0-1/2
L ubricants	0-4
L ubrication and maintenance	0-9/1
L ubrication and maintenance chart	0-9/3
L ubrication points	0-9/2

M ain bearing bolts, tightening of	00-1/1
M aintenance	
general	0-9/1
of air filter	09-8/1
of battery	15-4/1
of oil filter	18-9/2

M aintenance hints for	
generator	15-12/1
starter motor, installed	15-3/1

M arks for TDC and feed begin	
on flywheel	00-6/4
on pulley	00-6/3, 00-6/12

M ax. speed, unloaded	
adjusting	00-12/1
description	07-4/11
values	00-0/1

M easures for winter operation	0-7/1
M easuring of control rod travel	07-8/2

M echanical additional control	
checking and adjusting	07-9

M illing or cutting of	
cylinder crankcase	01-26/1
cylinder head	01-5/1

M inimum oil pressure	0-10/6
M ixing ratio of anti-freeze	0-7/1

M ixing table for fuels	0-7/2
M odel plate	21

Nozzle holder	
disassembly and assembly	07-18/1
removal and installation	07-17/1
Oil bath air filter	09-8/3
Oil circuit	18-1/1
Oil consumption too high	0-10/6
Oil deflector on crankshaft, front	03-1/2
Oil filling of	
engine (oil pan)	0-1/11
fan hub	0-4
water pump	0-4
Oil filter	
disassembly, cleaning and assembly	18-9/1
removal and installation	18-7/1
table	18-7/1
Oil loss	0-10/6
Oil pan	
removal and installation	01-21/1
table	01-21/2
Oil pressure	
during operation	0-1/2
minimum	0-10/6
too low	0-10/6, 18-1/4
Oil pressure relief valves	
general data, measures and tolerances	18-0/2
Oil pressure relief valve in oil filter	
checking disassembly and cleaning	18-9/5
Oil pressure relief valve in oil gallery	
cleaning and testing	18-5/1
removal and installation	18-3/1
table	18-5/2
Oil pump	
general data, measures and tolerances	18-0/1
removal and installation	18-11/1
repairing	18-14/1
table	18-11/2
Oil pump drive shaft	
general data, measures and tolerances	18-0/2
removal and installation	18-16/1
Opening begin	
of thermostat	20-0/1
Opening pressure of	
injection nozzle	07-18/5
low-pressure valve of cooling system	20-0/1
oil pressure relief valve, oil gallery	18-0/2
oil pressure relief valve, oil filter	18-0/2
overflow valve on fuel main filter	00-01, 09-3/3
pressure relief valve of cooling system	20-0/1
Operating hours counter, removal and installation	01-11/1
Operating temperature of	
cooling water	0-1/2, 0-2/1
lube oil	0-1/2, 0-2/1
Operation above 2000 m above sea level	07-5/3
Output diagrams	0-1/5
Output standard specifications	0-1/4, 07-5/2
Outputs of individual engines	0-1/11
Overflow valve	
designation	09-3/5
Peak pressure tester	07-18/7
Performance data, general	0-1/4

Pistons	
general data, measures and tolerances	03-0/4
removal and installation	03-11/1
with rings, fitting into cylinder	03-15/1
Plate valve	
in radiator cap	20-1/2
of overflow valve	09-3/4
Pneumatic governor	
adjusting	07-8/1
checking for leaks	07-8/1
description	07-4/4, 07-4/22
Position of crankshaft at feed begin	
of injection pump	00-0/1
Position of model plates and embossed engine number	21
Pre-chamber	
checking	01-1/3
removal and installation	01-1/1
Pre-glowing test	00-4/1
Pre-glowing times	0-7/3
Preservation of	
battery	0-8/2
engine	0-8/1
radiator	0-8/1
Preserved engines, taking into operation	0-8/3
Pressure lines, checking, cleaning and manufacturing	07-16/1
Pressure relief valve in	
cylinder crankcase (oil gallery)	18-5/2
oil filter	18-9/5
radiator cap	20-1/2
Pressure valve, description	07-4/3, 07-4/22
Pressure-testing of	
cylinder crankcase	01-26/2
cylinder head	01-5/2
Pulley	
on crankshaft, removal and installation	03-7/1
water pump, removal and installation	20-7/1
Push rods	
checking	05-3/1
removal and installation	05-1/1
Radiator cap	
general data, measures and tolerances	20-0/1
Reduced output	07-5/2
Regulator switch	
description	15-00/2
designation	15-0/2
Repair sizes for	
camshaft	05-0/6
camshaft bearings	05-39/1
crankshaft	03-0/1
crankshaft bearings	03-0/2
cylinder crankcase (cylinder bores)	01-0/5
pistons	03-0/4
valve guides	01-0/4
valve tappets	01-0/6
Revolution counter drive,	
removal and installation	01-12/1
Ring gear of flywheel, replacing	03-18/1
Rocker arms and rocker arm seats, OM 636	
disassembly, checking, repairing and assembly	05-2/1
general data, measures and tolerances	05-0/2
removal and installation	05-1/1

Rocker arms and rocker arm seats, OM 621	
disassembly, checking, repairing and assembly	05-6
general data, measures and tolerances	05-0/3
removal and installation	05-5/1
Rotation, sense of	0-1/1
Running and sound test	00-4/1
Running-in specifications	0-3/1
S ales designation	0-1/11
Seal on valve stems, replacing	05-16/1
Seal ring, front	
for crankshaft, removal and installation	03-3/1
Smoke tester	07-8/5
Smoking during starting	0-10/2
Solenoid switch, removal and installation	15-2
Speed ranges	07-4/10
Spray pattern of inj. nozzle, checking	07-18/5
Spray pressure of inj. nozzles	07-0/1, 07-18/5
Standard design of engine	0-1/11
Standard engine, view	27
Starter motor	
armature, checking for shorting to ground	15-5/1
armature, checking for short in winding	15-5/1
carbon brushes	15-3/1
checking power	15-5/2
commutator	15-3/1
description	15-00/2
disassembly and assembly	15-4/1
electrical testing	15-5/1
exciter winding, checking	15-5/1
fails to turn	0-10/1
general data, measures and tolerances	15-0/1
leads	0-1/3
maintenance hints	15-3/1
removal and installation	15-1/1
solenoid switch	15-2
table	15-1/2
trouble shooting	15-6/1
Starting of engine with low outside temperatures	0-7/2
Stroke advance, adjusting	07-5/7
Subsequent installation of	
injection timing device	07-27/1
oil rings, slotted with Goetze expander	03-15/3
service hour counter	01-11/1
valve stem seal	05-16/1
Switch (glow, starter and stop switch)	15-33/1
Switch positions of glow starter and stop switch	15-33/1
T able on	
cylinder head covers	01-3/5
diaphragms and governor springs	07-0/2
exhaust manifolds	14-8/2
fans	20-12/7
flywheels	03-16/2
fuel feed pumps	07-14/2
generators	15-11/3
glow plugs	15-30/1
governors of injection pumps	07-2/1
individual engines	0-1/11

injection pumps with governor and feed pump, installed up to date	07-2/1
intake lines	14-3
oil filters	18-7/1
oil pans	01-21/2
oil pumps	18-11/2
pistons and piston rings	03-0/3
pressure relief valves	18-5/2
pulleys of crankshaft	03-1/1
regulator switches of generators	15-0/2
starter motor	15-1/2
thermostat, cooling system	20-0/1
throttle ducts	07-23/2
timing housing covers	01-16/2
water pumps	20-8/2
Technical data, OM 636	0-1/1
Technical data, OM 621	0-2/1
Test sheets for injection pumps and governors	07-1/5
Test stand for injection pumps	07-5/4
Testing values for injection pumps	07-1/1
Thermostat, cooling water	20-0/1
Throttle duct	
checking and repairing	07-23/1
description	07-4/4
general data, measures and tolerances	07-0/4
removal and installation	07-21/1, 14-1/1
table	07-23/2
Ticking noise in the fuel system	09-3/4
Tightening torques	00-1/1
Timing gears	
general data, measures and tolerances	05-0/5
removal and installation	05-31/1
Timing housing cover	
checking and re-machining	01-16/1
removal and installation	01-15/1
table	01-16/2
Timing of valves	
at 0.4 mm test valve clearance	00-0/2
checking	00-8/1
Torque	0-1/5
Total weight of engine	0-1/2
Treating agents for cooling water	0-6/1
Trouble shooting	
general	0-10/1
generator	15-17/1
starter motor	15-6/1
Type designation and list	23, 0-1/11, 0-2/1
Type plate with engine number	21
V acuum line, removal and installation	07-15/1
Vacuum valve in radiator cap	20-1/2
Valves	
general data, measures and tolerances	05-0/1
grinding	05-13/1
removal and installation	05-11/1
Valve clearance	
adjusting	00-3/1
values	00-0/1
Valve guides, checking and replacing	01-6/1
Valve seat ring, replacing of	01-7/1
Valve seats, machining	01-7/1
Valve springs	
checking	05-14
general data, measures and tolerances	05-0/1

Valve tappets	
checking	05-9
general data, measures and tolerances	05-0/2
removal and installation	05-8/1
Valve timing, checking of	00-8/1
V-belts	
checking and adjusting tension	20-6/2
dimensions	20-6/2
removal and installation	20-6/1
Versions of	
control springs	07-0/3
cylinder head covers	01-3/5
diaphragms and control springs	07-0/2
exhaust manifolds	14-3/1
fans	20-12/7
flywheels	03-16/2
fuel feed pumps	07-14/2
generators	15-11/3
glow plugs	15-30/1
governors of injection pumps	07-2/1
individual engines	0-1/11
injection pumps with governor and feed pump	07-2/1
intake lines	14-3
oil filters	18-7/1
oil pans	01-21/2
oil pressure relief valves	18-5/2

oil pumps	18-11/2
overflow valves	09-3/5
pulleys of crankshaft	03-1/1
starters	15-1/2
throttle ducts	07-23/2
timing housing covers	01-16/2
water pumps	20-8/2
View of complete engine	27

W ater pump	
disassembly and assembly	20-8/2
grease or oil filling	0-4
pulley, removal and installation	20-7/1
removal and installation	20-5/1
repairing	20-8/1
table	20-8/2
Wet-type air filter	09-8/2
Winter operation	0-7/1
Wire cable for idle run adjustment	00-11/2
Wire cable from glow starter switch to injection pump, adjusting of	00-13/1
Wiring diagram of	
electrical system	15-00/1
glow plug system	15-00/4

Notes

Notes

Umrechnungstabellen

Conversion Tables

Längenmaße Linear Measure

Millimeter in Zoll Millimeters to inches	1 mm = 0.0394 in.
Zentimeter in Zoll Centimeters to inches	1 cm = 0.394 in.
Meter in Fuß Meters to feet	1 m = 3.281 ft.
Meter in Yard Meters to yards	1 m = 1.094 yds.
Kilometer in Meilen Kilometers to statute miles	1 km = 0.621 stat. mile

Flächenmaße Square Measure

Quadratmillimeter in Quadratzoll Square millimeters to square inches	1 mm ² = 0.0015 sq. in.
Quadratzentimeter in Quadratzoll Square centimeters to square inches	1 cm ² = 0.155 sq. in.

Raummaße Cubic Measure

Kubikzentimeter in Kubikzoll Cubic centimeters to cubic inches	1 cm ³ = 0.0610 cu. in.
Kubikdezimeter in Kubikzoll Cubic decimeters to cubic inches	1 dm ³ = 61.023 cu. ins.

1 dm³ = 1 l (Liter)

Hohlmaße Liquid Measure

Liter in Pint – Liters to pints	1 l = 2.113 US pints
	1 l = 1.759 Imperial pints
Liter in Quart – Liters to quarts	1 l = 1.057 US quarts
	1 l = 0.88 Imperial quart
Liter in Gallonen – Liters to gallons	1 l = 0.2642 US gal.
	1 l = 0.22 Imperial gal.

Gewichtsmaße
Weight

Gramm in Unzen Grams to ounces	1 g = 0.0353 oz.
Kilogramm in Pfund Kilograms to pounds	1 kg = 2.206 lbs.

Druckmaße
Pressure

Kilogramm pro Quadratcentimeter in Pfund pro Quadratzoll Kilograms per square centimeter to pounds per square inch	1 kg/cm ² (at) = 14.22 lbs./sq. in. (psi)
Millimeter Quecksilbersäule in Zoll Quecksilbersäule Millimeters Hg to inches Hg	1 mm QS (Hg) = 0.0394 in. Hg.

0 mm QS (Hg) = 0. in. Hg
760 mm QS (Hg) = 29.92 ins. Hg

Temperaturmaße
Temperature

Grad Celsius in Grad Fahrenheit Degrees centigrade to degrees Fahrenheit	$^{\circ}\text{C} \cdot \frac{9}{5} + 32 = ^{\circ}\text{F}$
---	--

Drehmomentmaße
Torque

Meterkilogramm in Fußpfund Kilogram-meter to foot-pounds	1 mkg = 7.233 ft. lbs.
---	------------------------

Geschwindigkeitsmaße
Speed

Kilometer pro Stunde in Meilen pro Stunde Kilometers per hour to miles per hour	1 km/h = 0.621 miles/h (mph)
Meter pro Sekunde in Fuß pro Sekunde Meters per second to feet per second	1 m/s = 3.281 ft./s (fps)

Verbrauch
Consumption

Liter pro 100 Kilometer in Meilen pro US-Gallone bzw. Imperial Gallone Liters per 100 Kilometers to miles per US-gallon or miles per Imperial-gallon, resp.	$\frac{235}{1/100 \text{ km}} = \text{miles/US gal.}$ $\frac{282}{1/100 \text{ km}} = \text{miles/Imp. gal.}$
--	---

Beispiel: Verbrauch 8 l/100 km = ? miles/US gal.
Example: Consumption $\frac{235}{8 \text{ l}/100 \text{ km}} = 235 : 8 = 29.37 \text{ miles/US gal.}$

Conversion Table

Millimeter to Inches

Millimeter – Millimeters										
	0,00	0,01	0,02	0,03	0,04	0,05	0,06	0,07	0,08	0,09
mm	Zoll – Inches									
0	0	.000 394	.000 787	.001 181	.001 575	.001 969	.002 362	.002 756	.003 150	.003 543
0,1	.003 937	.004 331	.004 724	.005 118	.005 512	.005 906	.006 296	.006 693	.007 087	.007 480
0,2	.007 874	.008 268	.008 661	.009 055	.009 449	.009 843	.010 236	.010 630	.011 024	.011 417
0,3	.011 811	.012 205	.012 598	.012 992	.013 386	.013 780	.014 173	.014 567	.014 961	.015 354
0,4	.015 748	.016 142	.016 535	.016 929	.017 323	.017 717	.018 110	.018 504	.018 898	.019 291
0,5	.019 685	.020 079	.020 472	.020 866	.021 260	.021 654	.022 047	.022 441	.022 835	.023 228
0,6	.023 622	.024 026	.024 409	.024 803	.025 197	.025 591	.025 984	.026 378	.026 772	.027 165
0,7	.027 559	.027 953	.028 346	.028 740	.029 134	.029 528	.029 921	.030 315	.030 709	.031 102
0,8	.031 496	.031 890	.032 283	.032 677	.033 071	.033 465	.033 858	.034 252	.034 646	.035 039
0,9	.035 433	.035 827	.036 220	.036 614	.037 008	.037 402	.037 795	.038 189	.038 583	.038 976

Millimeter – Millimeters										
	0	1	2	3	4	5	6	7	8	9
mm	Zoll – Inches									
0	0	0.039 370	0.078 740	0.118 110	0.157 480	0.196 850	0.236 220	0.275 591	0.314 961	0.354 331
10	0.393 701	0.433 071	0.472 441	0.511 811	0.551 181	0.590 551	0.629 921	0.669 291	0.708 661	0.748 031
20	0.787 402	0.826 772	0.886 142	0.905 512	0.944 882	0.984 252	1.023 622	1.062 992	1.102 362	1.141 732
30	1.181 102	1.220 472	1.259 843	1.299 213	1.338 583	1.377 953	1.417 323	1.456 693	1.496 063	1.535 433
40	1.574 803	1.614 173	1.653 543	1.692 913	1.732 283	1.771 654	1.811 024	1.850 394	1.889 764	1.929 134
50	1.986 504	2.007 874	2.047 244	2.086 614	2.125 984	2.165 354	2.204 724	2.244 094	2.283 465	2.322 835
60	2.362 205	2.401 575	2.440 945	2.480 315	2.519 685	2.559 055	2.598 425	2.637 795	2.677 165	2.716 535
70	2.775 906	2.795 276	2.834 646	2.874 016	2.913 386	2.952 756	2.992 126	3.031 496	3.070 866	3.110 236
80	3.149 606	3.188 976	3.228 346	3.267 717	3.307 087	3.346 457	3.385 827	3.425 197	3.464 567	3.503 937
90	3.543 307	3.582 677	3.622 047	3.661 417	3.700 787	3.740 157	3.779 528	3.818 898	3.858 268	3.897 638

mm	100	200	300	400	500	600	700	800	900	1000
Zoll-Inches	3.937 008	7.874 016	11.811 024	15.748 031	19.685 039	23.622 047	27.559 055	31.496 063	35.433 071	39.370 079

Example: 2860,35 mm = ? Zoll — Inches

2000 mm = 2 x 1000 mm = 2 x 39.370 079 = 78.740 158 "

800 mm = 31.496 063 "

60 mm = 2.362 205 "

0,35 mm = 0.013 780 "

2860,35 mm = 112.612 206 "

Location of Model Plates and Punched-in Engine Number

A. OM 636

Location of engine plate with model identification, type identification, and engine serial number (see Figure 1 and 6).

Location of punched-in engine number on crankcase (see Figure 3).

Location of model plates for the injection pump, for the governor, and for the fuel feed pump (see Figure 2).

Please specify the following complete details in all inquiries and spare part orders made by letter or by telephone, by this you eliminate unnecessary waiting time and our time-wasting inquiries:

a) For Vehicle Engines

1. The complete engine number [the model identification (a), the type identification (b), and the engine serial number (c), see Figure 1 and 4], e.g. OM 636 VII/636.930 7500530.
2. The complete chassis number (e.g. 180D / 120 110 75 00010).
3. The mileage covered and/or the hours of operation.
4. Date of vehicle registration.

b) For Built-in Engines

1. The complete engine number (as under a) also see Figure 3 and 5).
2. The mileage covered and/or the hours of operation.

Note: If engines with operating hour counter are installed in vehicles also equipped with odometer, **then the operating hours must always be specified.**

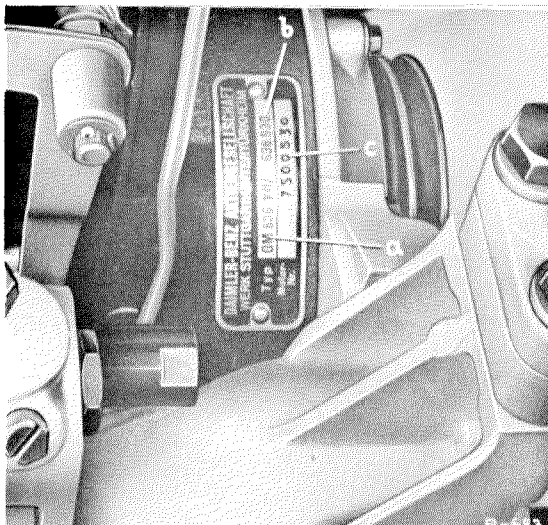

Figure 1

a Model identification
b Type identification (consisting of type and version)
c Engine serial number
On engines for right-hand steering the type identification has the prefix "R" on this model plate design: e.g. R 636.930

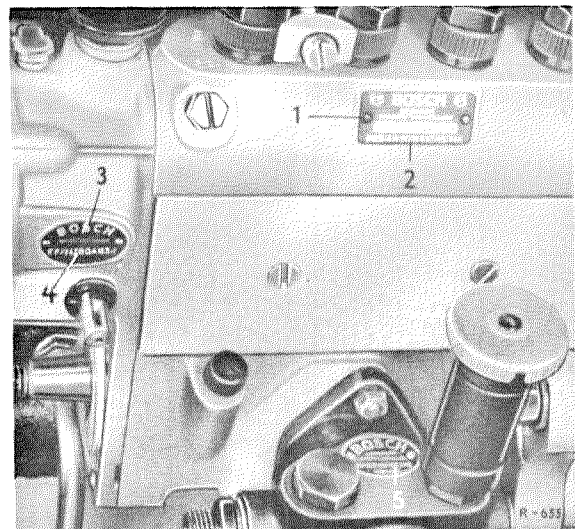
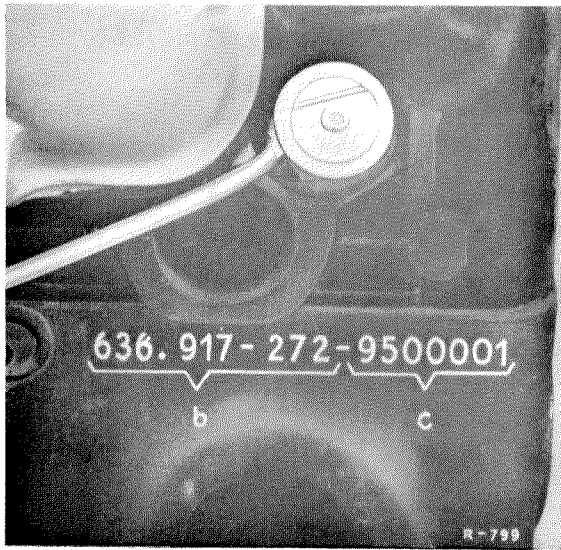

Figure 2

1 Model plate of injection pump
2 Identification of fuel feed pump
3 Model plate of governor
4 Identification of governor
5 Model plate of fuel feed pump with identification of fuel feed pump

When replacing or ordering injection pumps, injection pump governors, and fuel feed pumps, as well as when testing these units on the injection pump test stand, the Bosch designations indicated on the model plate must be carefully observed.



In addition to the details on the model plate the complete type identification (b) and the engine serial number (c) are punched on the rear left side of the crankcase directly below the cylinder head (see Figure 3). The punched-in numbers on the model plate and on the crankcase must be the same.

Figure 3

b Complete type identification
c Engine serial number
(also see Figure 5 and 4)

Note: When replacing the engine, the model plate must be transferred to the new engine, so that the engine number listed in the registration papers need not be changed. Furthermore, the engine number punched on the crankcase of the new engine must be ground off and has to be replaced by punching in the engine number and/or the complete type identification (b) and the engine serial number (c) of the removed engine.

Recently, the 6-figure type identification contained in the engine number of the engine with the

Type identification 636.	}	914
		917
		919
		930
		934

was separated by a dash, and two further identification figures were added in 7th and 8th place (see Figure 4).



Figure 4

a = Model identification

b = Complete type identification

The individual figures of the type identification indicate digits 1, 2, and 3 (636) = Model

Digits 4, 5, and 6 (e.g. 930) = Version
 Digit 7 is the first identification figure (series 0–9).
 The individual identification figure in 7th place means:
 0 – Version without special feature
 1 – Version for left-hand steering, standard
 2 – Version for right-hand steering, standard

In 8th place is the second identification figure (series 0–9).
 The individual identification figure in 8th place means:
 0 – Version for standard clutch
 1 – Version for automatic fluid clutch
 2 – Version for automatic transmission

c = Engine serial number

The figures in digits 9 through 15 indicate the engine serial number.

On the built-in engines which do not correspond to the standard version with the type identification 636.917–00, a third identification figure was added in position 9 and also the power output in HP with the respective speed in r.p.m. (see Figure 5).

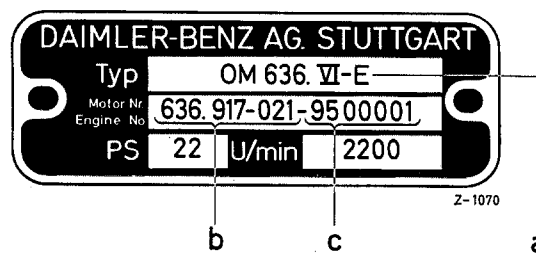

Figure 5

a = Model identification

b = Complete type identification

The individual figures of the type identification mean:

- digits 1, 2, and 3 (636) = Model
- digits 4, 5, and 6 (e.g. 917) = standard version of built-in engine
- digits 7 and 8 (e.g. 02) = identification figure of customer's version (built-in engine for enterprise X)
- digit 9 (e.g. 1) = identification figure for variant of customer's version (1 = first customer's variant of enterprise X).

On these engines with a third identification figure in 9th place, the identification figures in 7th and 8th place were combined to a two-digit identification figure of the series 00 to 99 and indicate the different customer's versions. In addition, the third identification figure in 9th place indicates the different variants of the individual customer's versions.

c = Engine serial number

The figures in digit 10 through 16 indicate the engine serial number.

On the engines of the type 636.932, 636.933, and 636.936 the model plate is attached to the rear of the crankcase (see Figure 6).

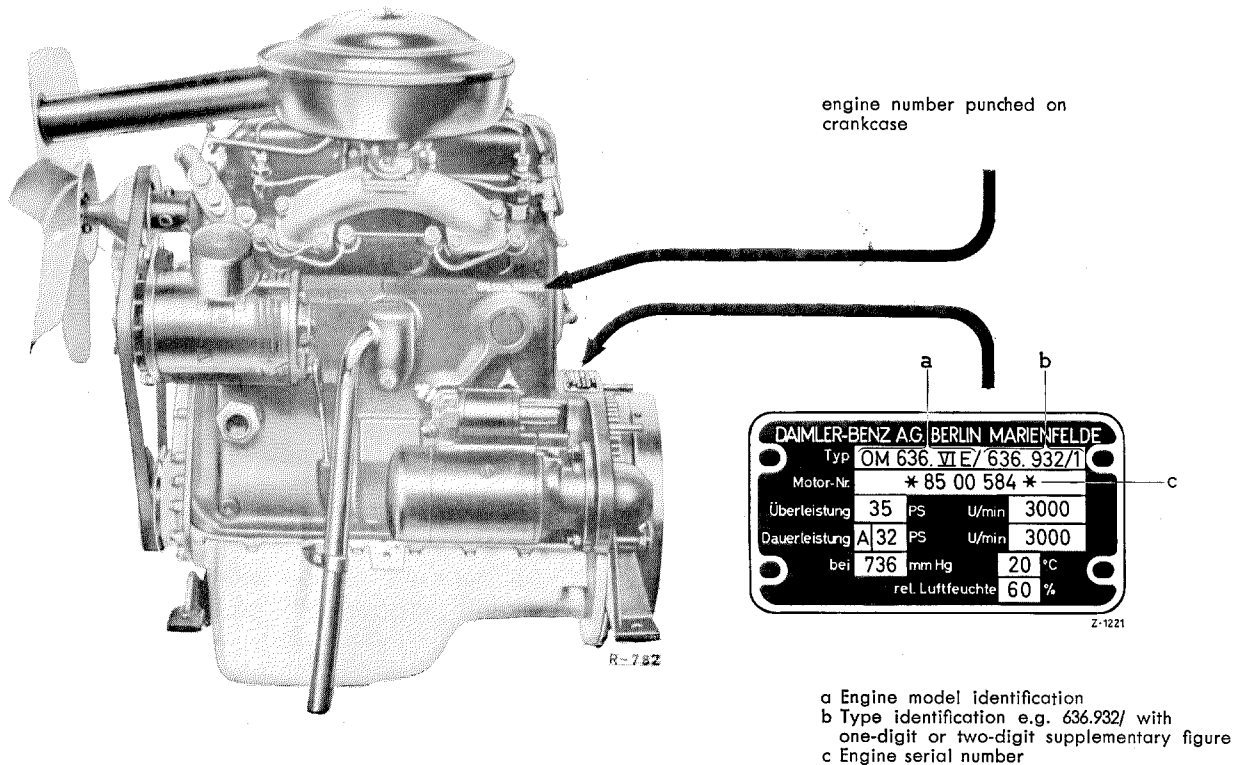

Figure 6

a = Model identification

b = Complete type identification

The individual figures of the type identification mean
 digits 1, 2, and 3 (636) = type
 digits 4, 5, and 6 (e.g. 932) = version

In 7th place is an identification figure (series 1-9)

The individual identification figures in 7th place mean:

- 1 Pressure circulation cooling, heat exchanger, centrifugal pump, and electric starting
- 3 Pressure circulation cooling, heat exchanger, centrifugal pump, and inertia starting
- 5 Pressure circulation cooling, radiator, fan (ventilator) and electric starting

c = Engine serial number

The figures in digits 8 through 14 indicate the engine serial number.

B. OM 621

Location of Model Plates and Punched-in Engine Number (see fig. 7).

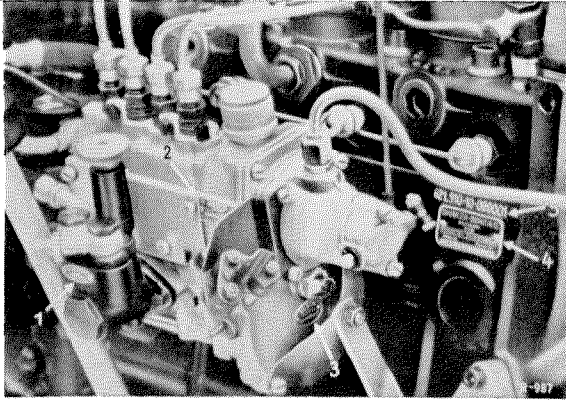

Figure 7

- 1 Model plate of fuel feed pump
- 2 Model plate of injection pump
- 3 Model plate of injection pump governor
- 4 Engine model plate
- 5 Engine number punched in cylinder crankcase

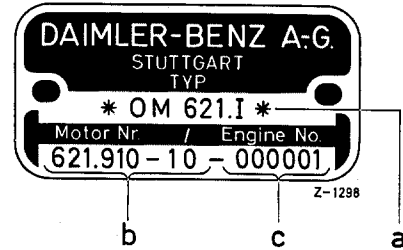

Figure 8

- a Engine model identification
- b Type identification, e.g. 621.910-10 with 2-digit additional figure
- c Engine serial number

a = Model identification

b = Complete type identification with 2 digits added

The individual figures of the type identification mean:

digits 1, 2, and 3 (621) = Model

digits 4, 5, and 6 (e.g. 910) = version

In 7th place is the first identification figure (0-9)

The individual identification figures in 7th place mean:

0 - version without special feature

1 - version for left-hand steering, standard

2 - version for right-hand steering, standard

In 8th place is the second identification figure (0-9)

The identification figure in 8th place means:

0 - version for standard clutch

1 - version for hydraulic automatic clutch

2 - version for automatic transmission

c = Engine serial number

The figures in 9th through 14th place indicate the engine serial number.

Built-in Engine Model OM 636.VI-E
Standard Version with the Type Identification 636.917-00
Injection Pump with Pneumatic Governor

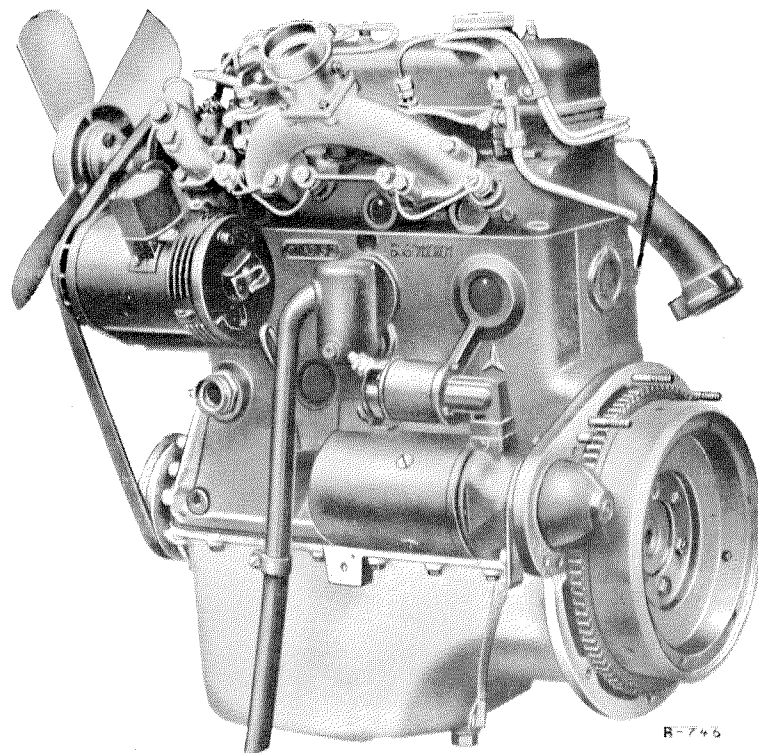
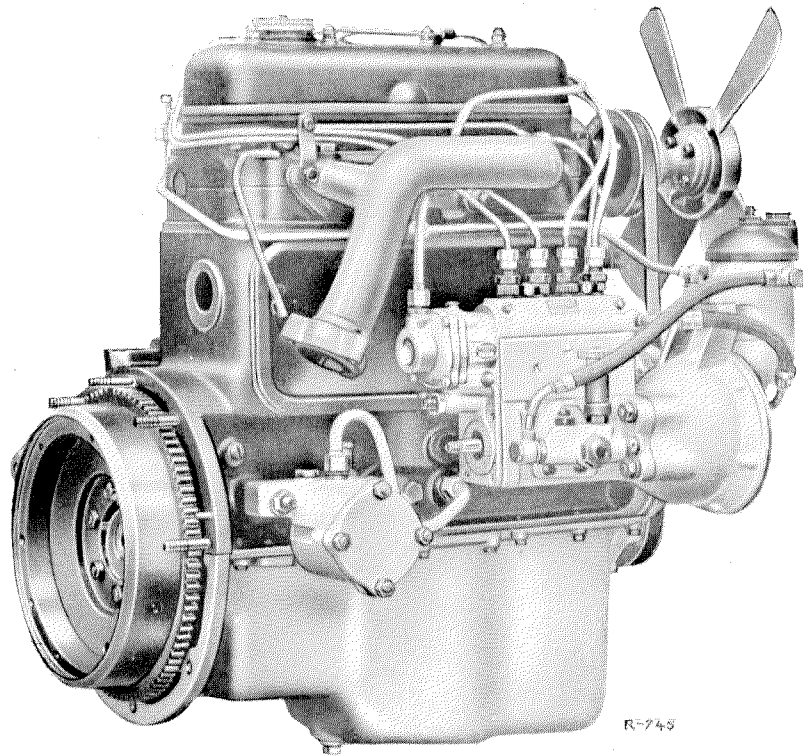

Built-in Engine Model OM 636.VI-E with the Type Identification 636.917-022 or (636.917/28)
Injection Pump with Centrifugal Governor, Fuel Feed Pump with Pre-cleaner

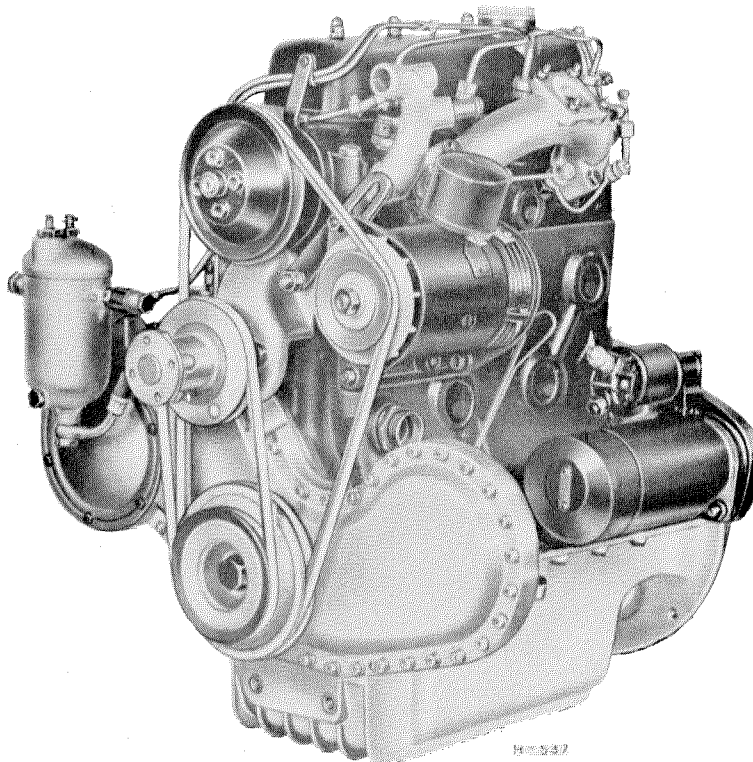
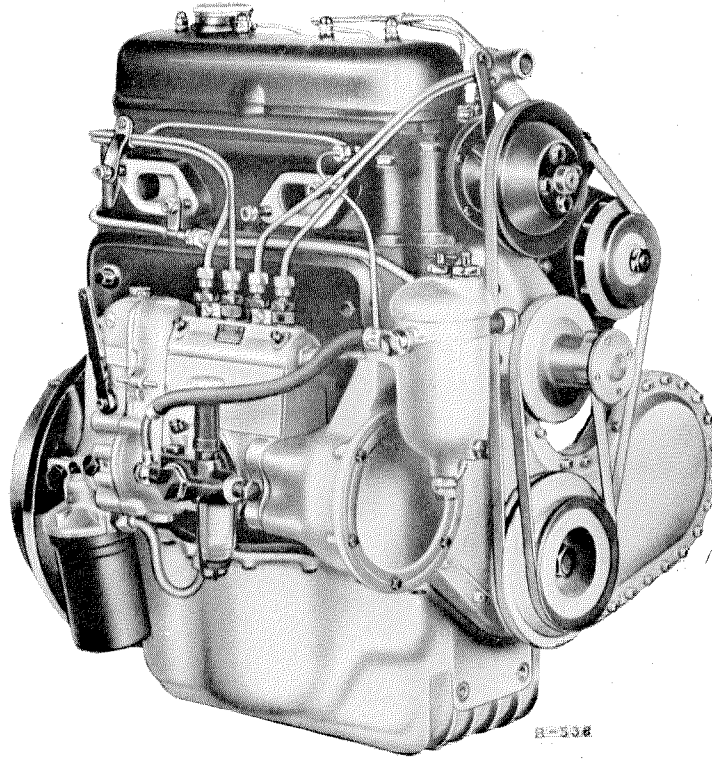

Engine Model OM 636.VI-U with the Type Identification 636.912 or 636.914
for the Universal Motor Vehicle "Unimog"

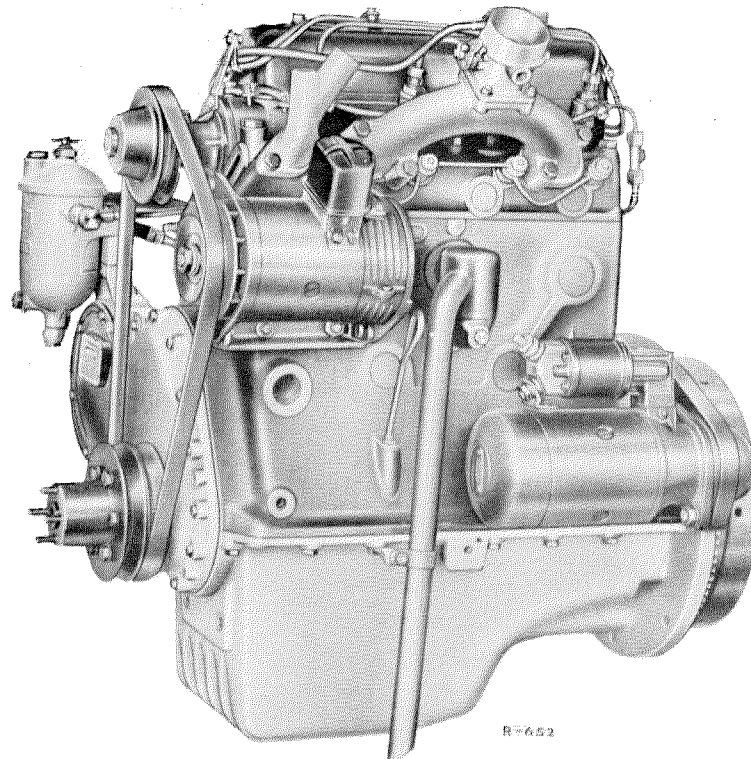
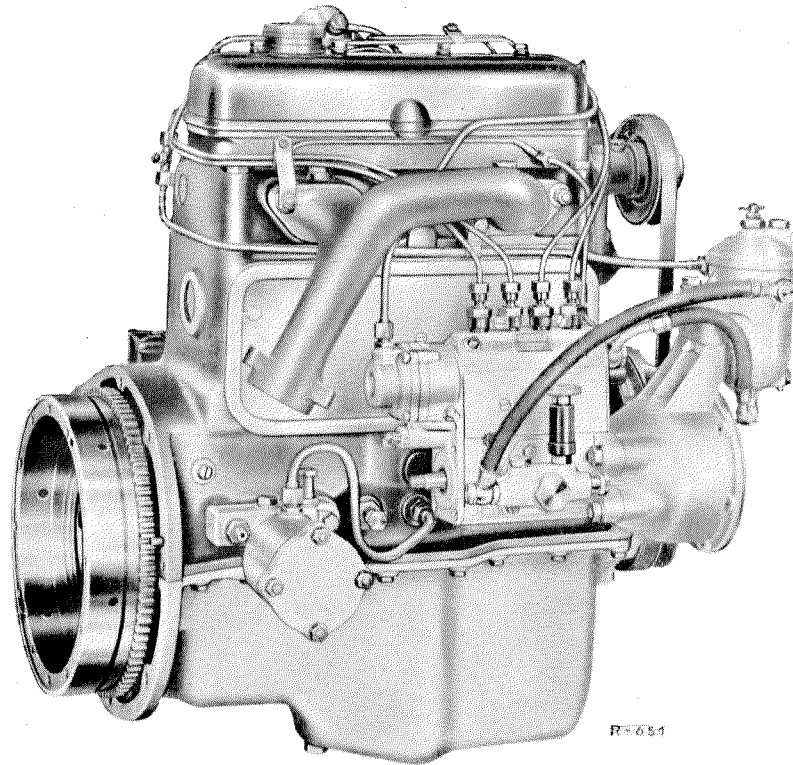

Engine Model OM 636.I Type 636.915
and
Engine Model OM 636.VI Type 636.916
for Vehicle Model 170 D and 170 Da
(with cylinder head for two short cylinder head covers)

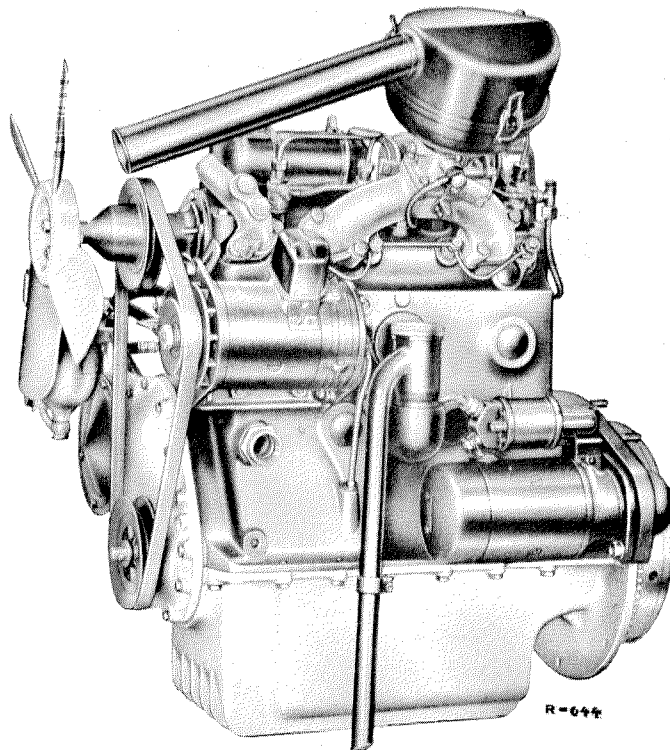
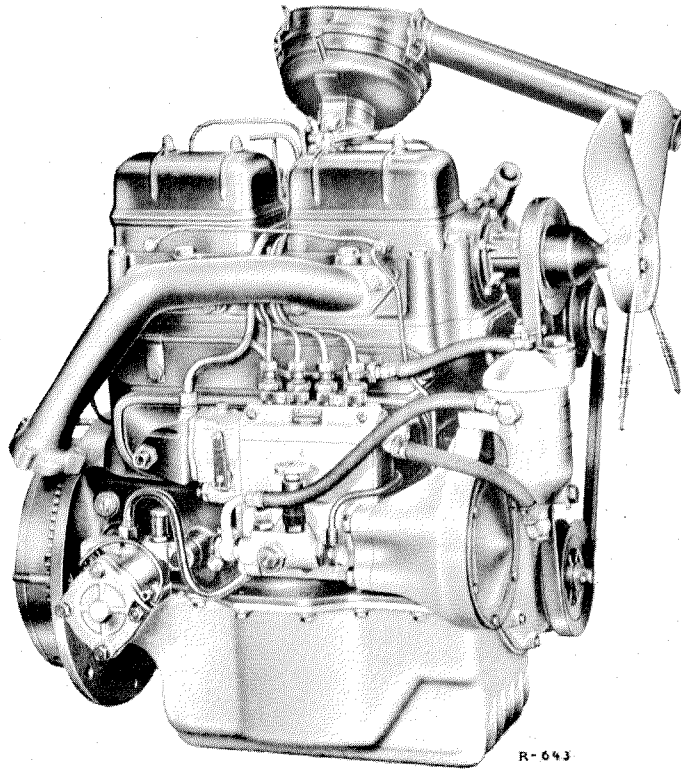

**Engine Model OM 636.VI Type 636.916
for Vehicle Model 170 Da and 170 Db
(with cylinder head for one long cylinder head cover)**

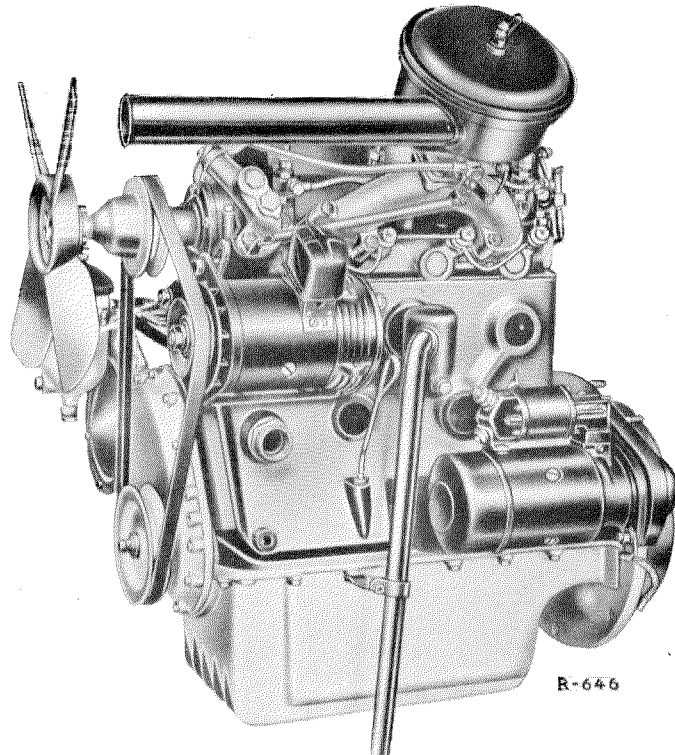
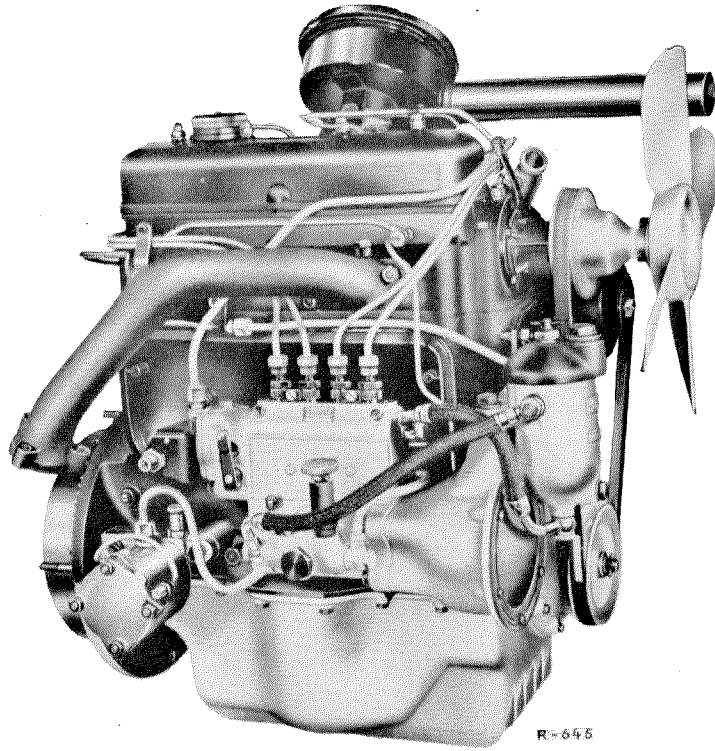

**Engine Model OM 636.VI Type 636.918
and
Engine Model OM 636.VIII Type 636.931
for Vehicle Model 170 DS and SD**

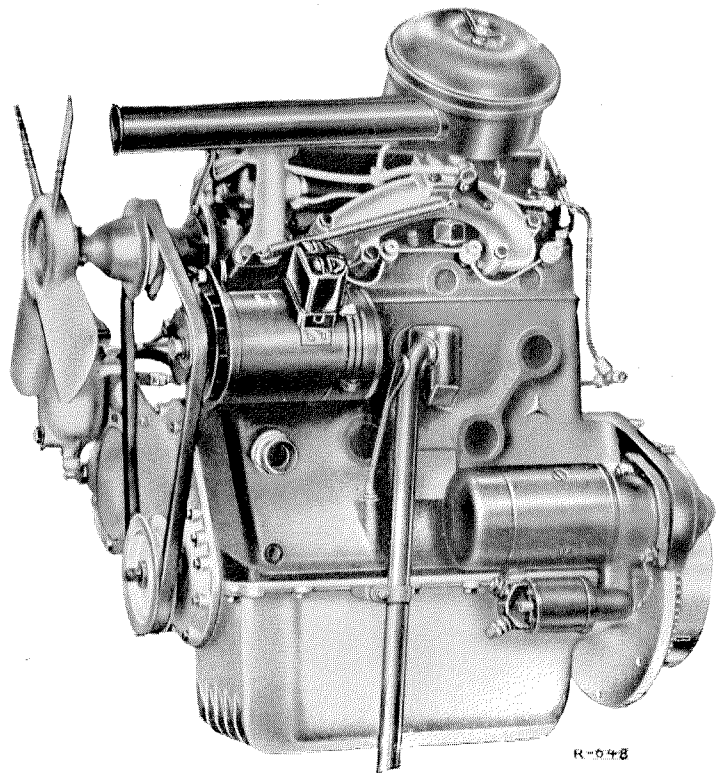
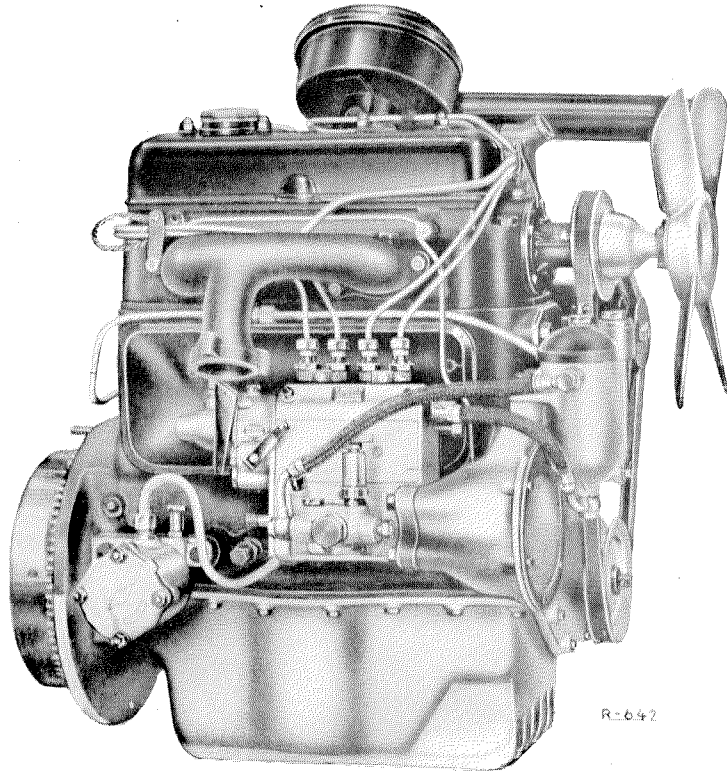

**Engine Model OM 636.VII Type 636.919
for Vehicle Model L 319 D**

without Injection Timing Device
with Injection Timing Device for Vehicle Model O 319 D Type 636.934

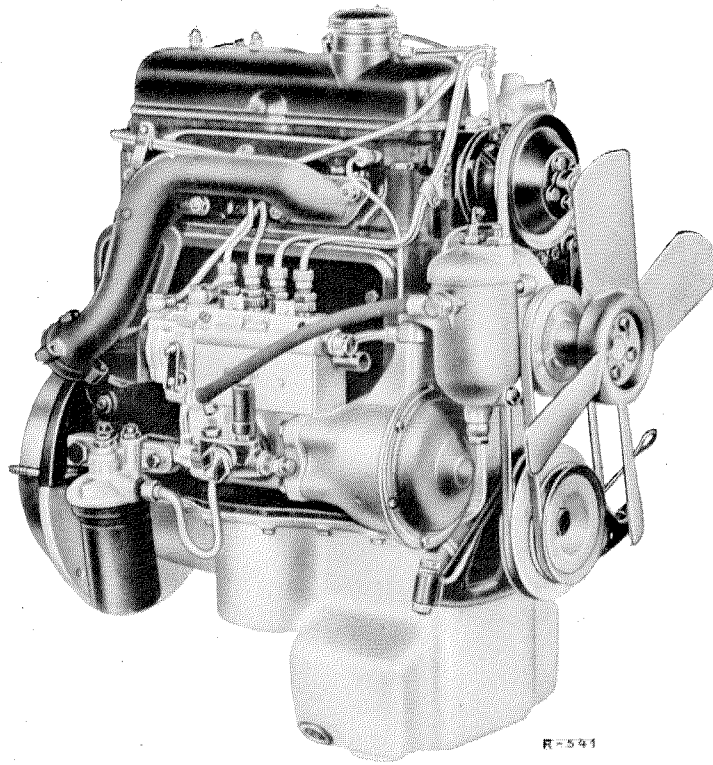

R-541

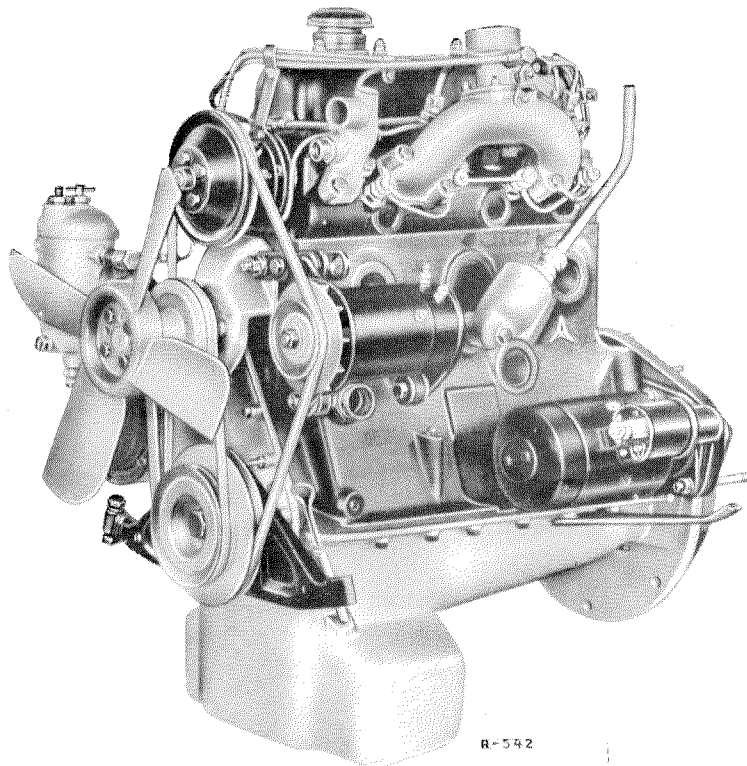

R-542

Engine Model OM 636.VII Type 636.930
for Vehicle Model 180 D

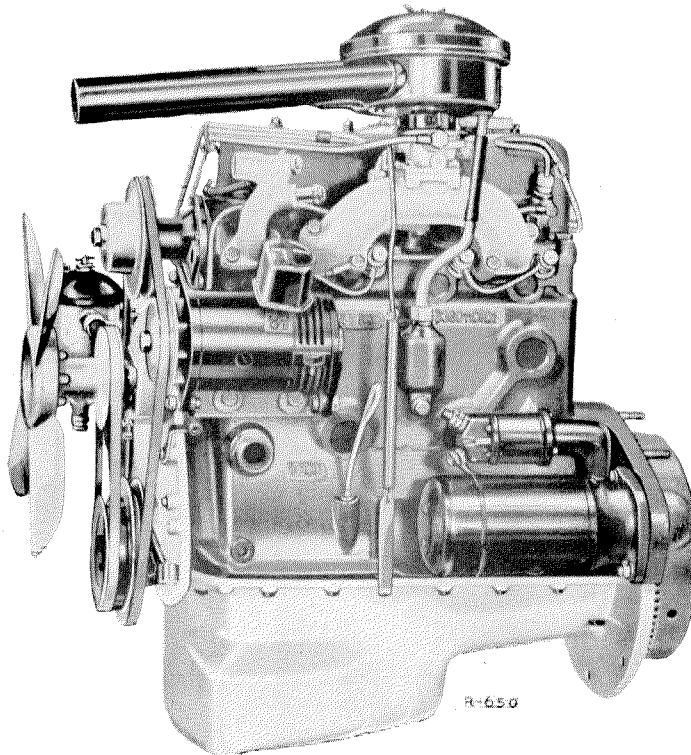
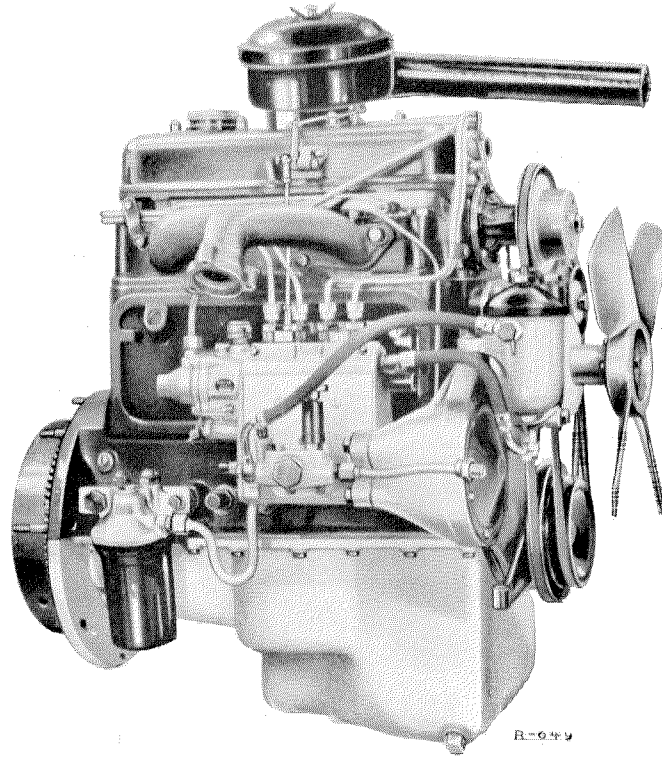

**Built-in Engine Model OM 636.VI-E with the Type Identification 636.933
for the Plant Berlin-Marienfelde**

Injection Pump with Centrifugal Governor

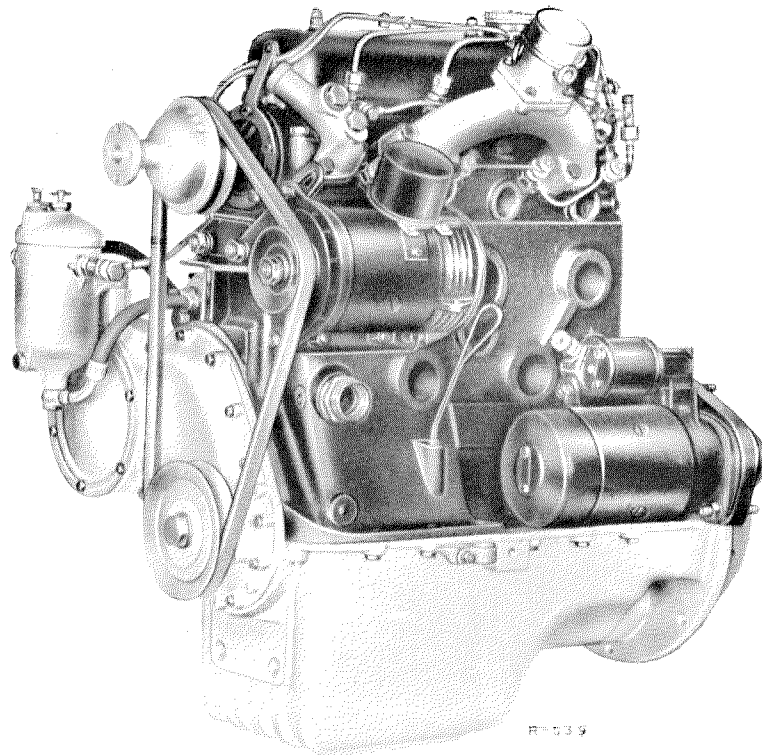
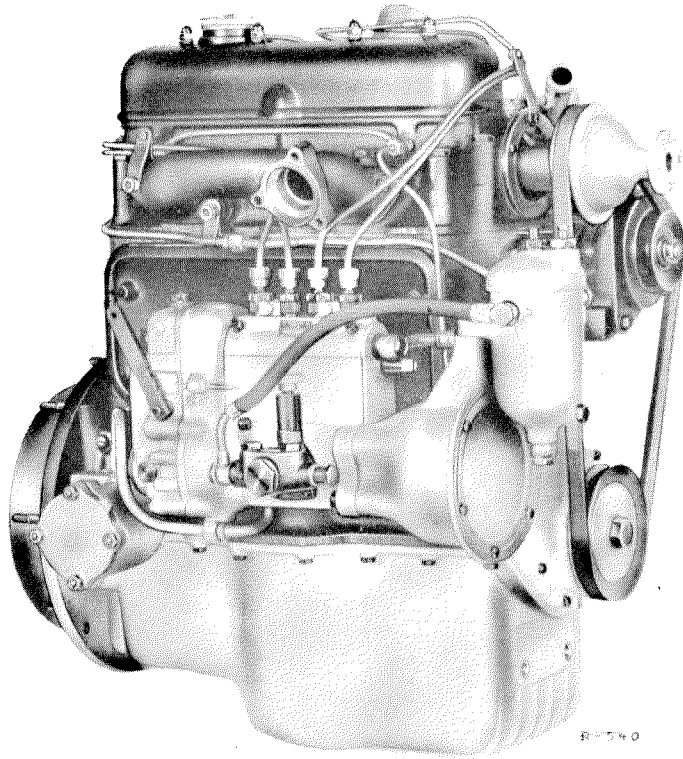

Engine OM 636.VI-U
with the Type Identification 636.912 or 636.914 (Unimog)

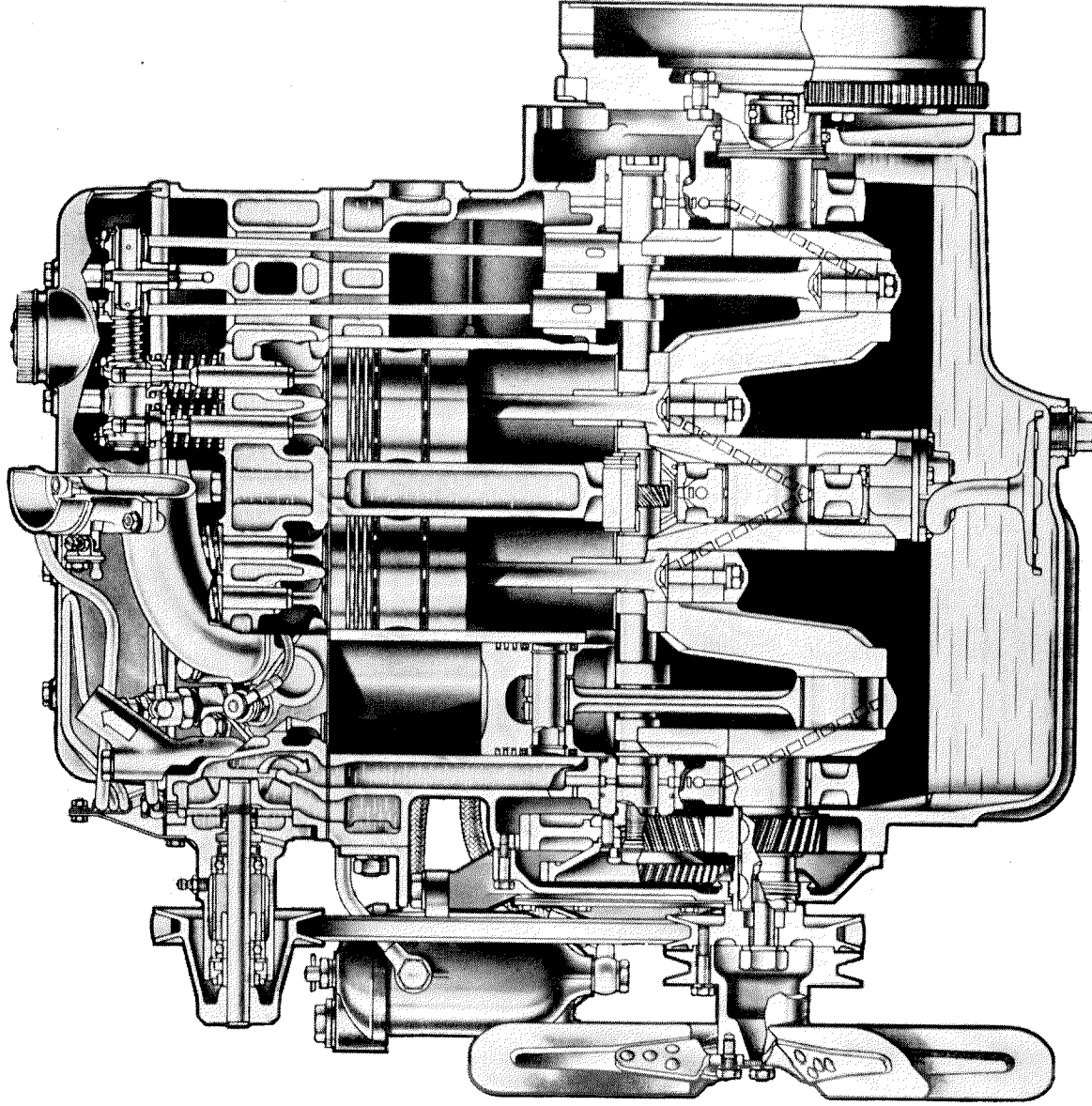

Engine (longitudinal section)

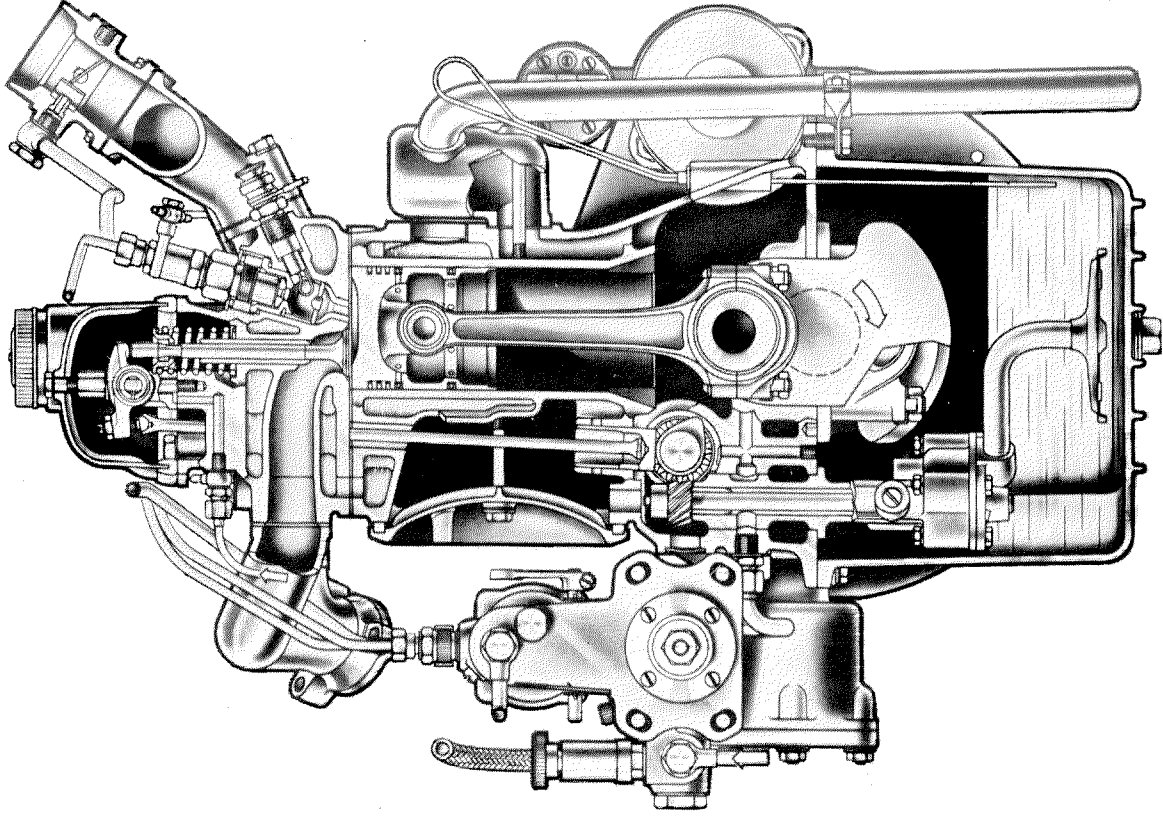

Engine (cross section)

**Engine Model OM 621.1 Type 621.910
for Vehicle Models 190 D and 190 Db**

Change: Engines on pages 38 to 42 added

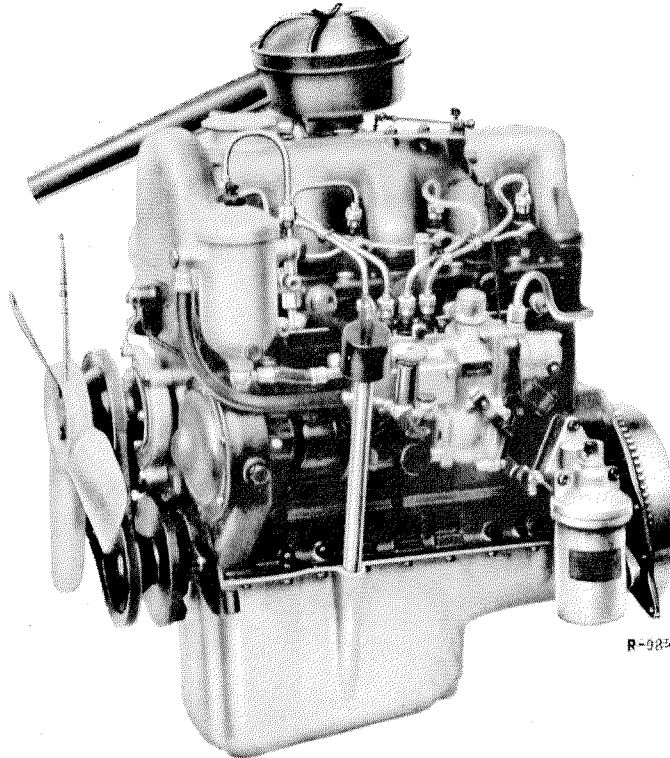

R-982

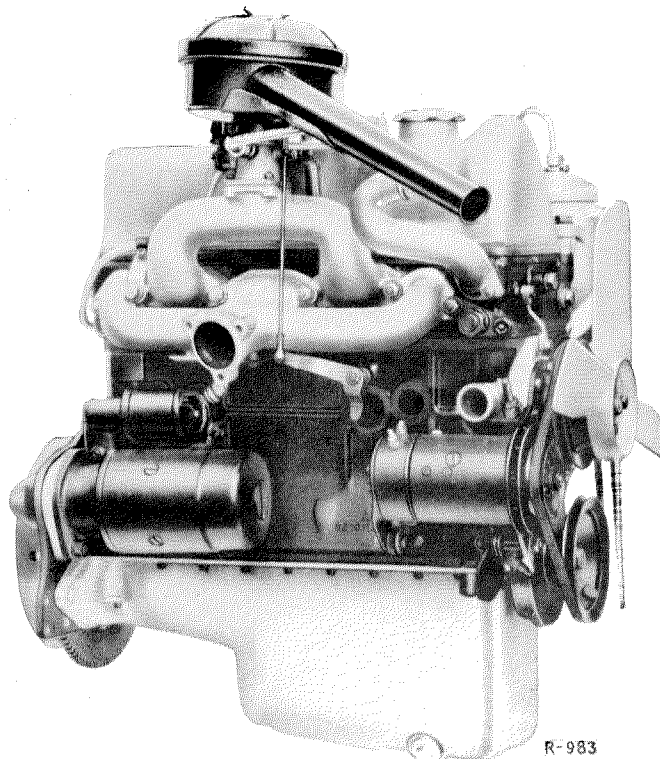

R-983

**Engine Model OM 621.III Type 621.912
1st Design with standard suction pipe
for vehicle model 190 Dc**

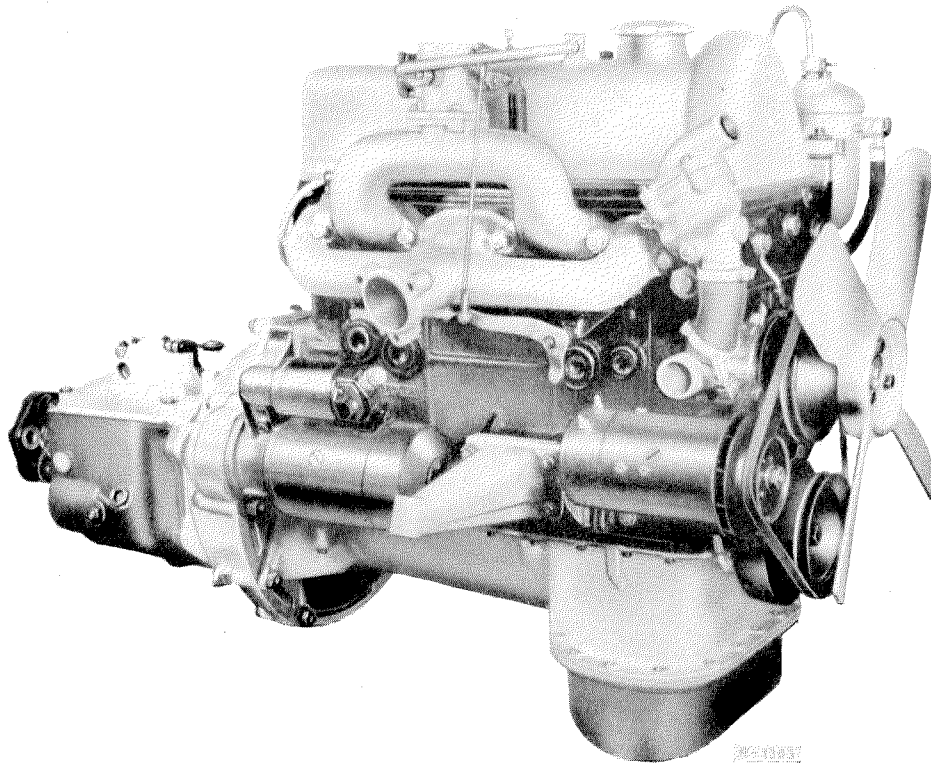
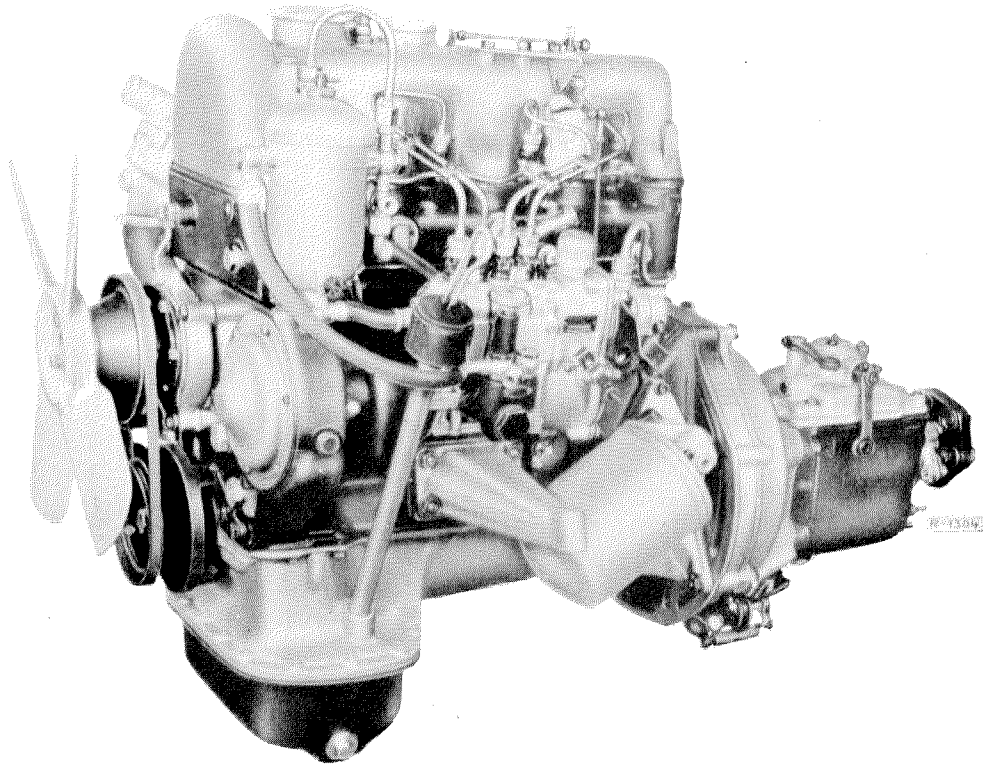

Engine Model OM 621.III Type 621.912
2nd Design with swing suction pipe
for vehicle model 190 Dc

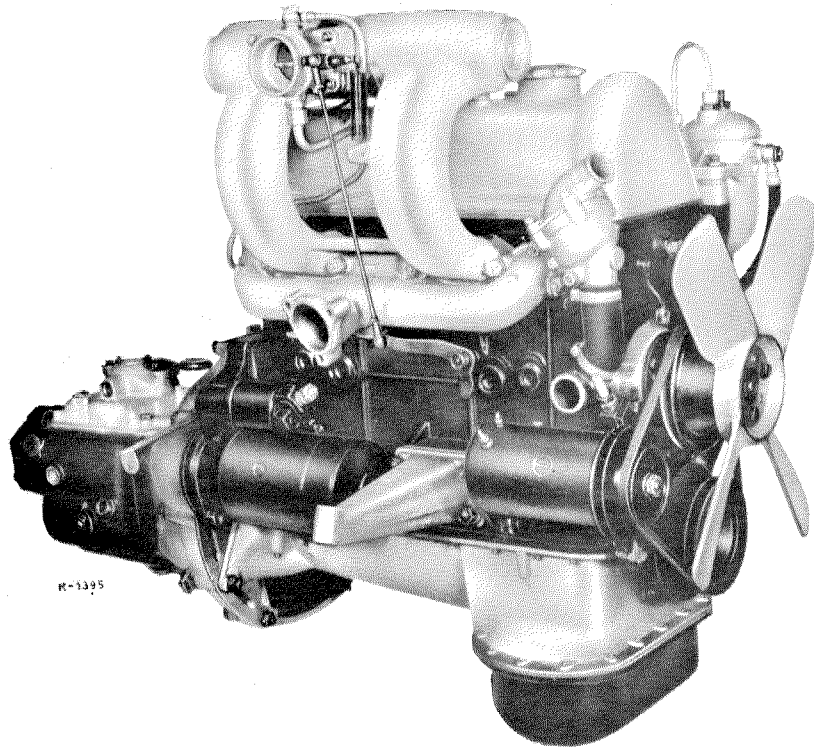
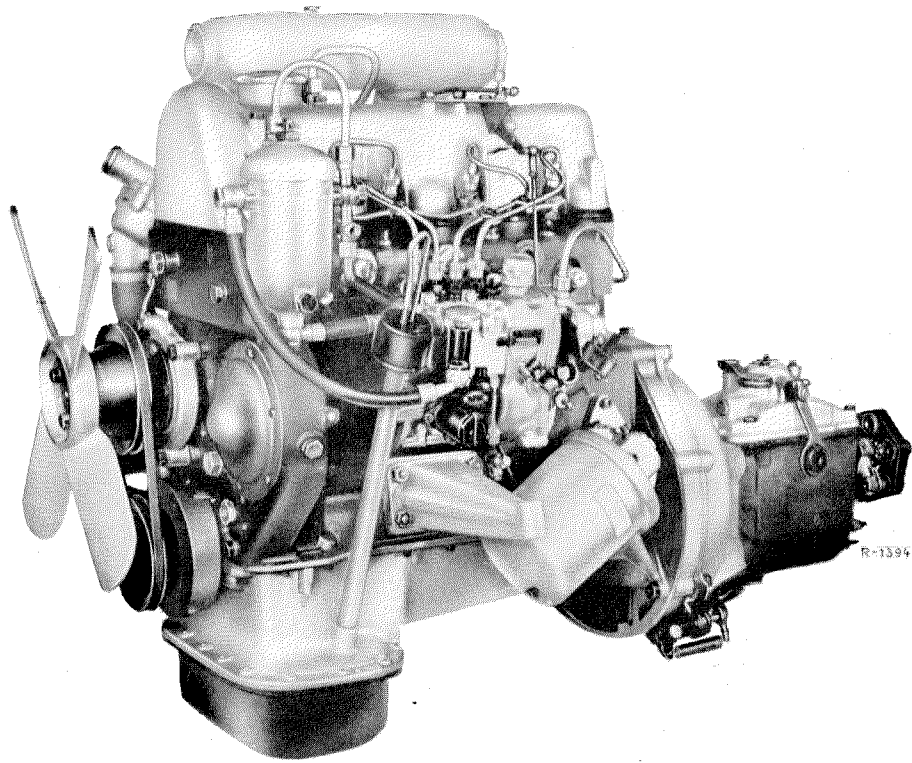

Engine Model OM 621.II Type 621.913
for vehicle models L and O 319 D

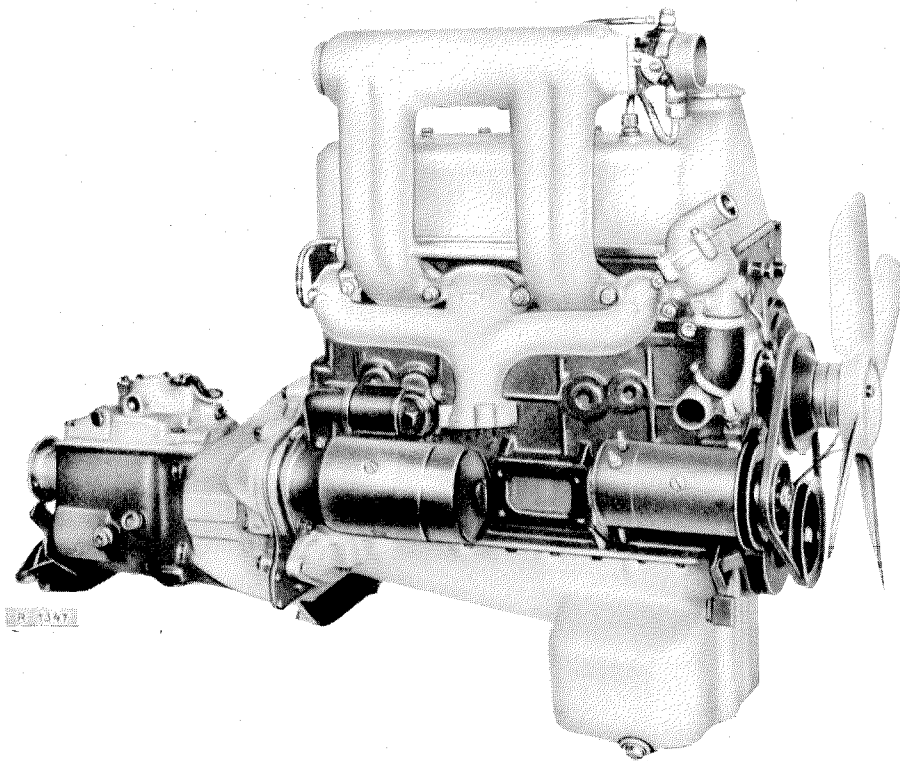
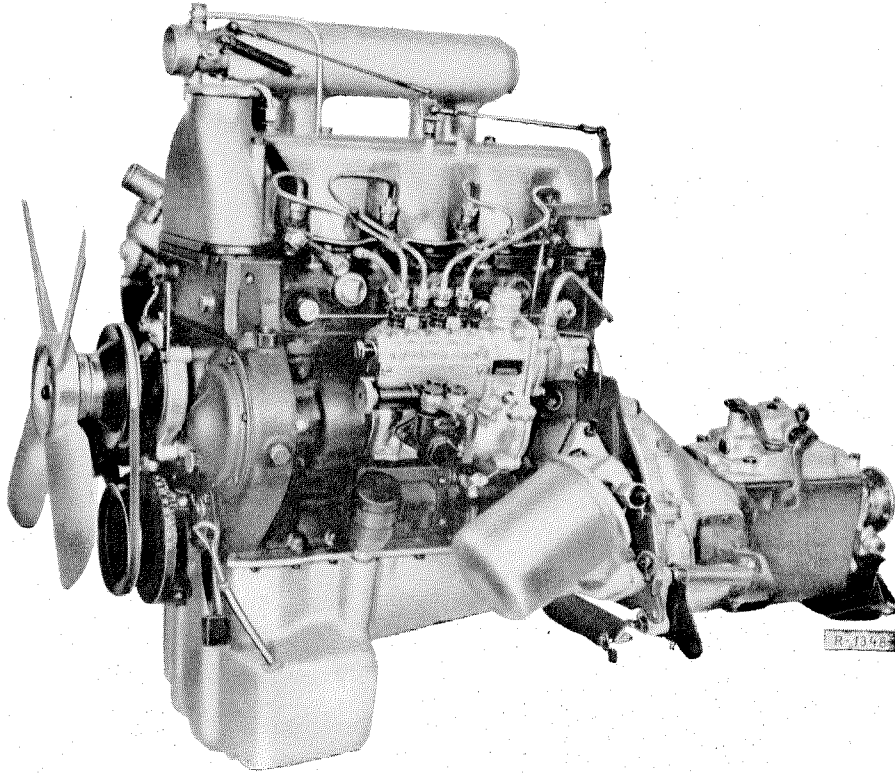

Engine Model OM 621.IV Type 621.914
for Vehicle Model 180 Dc

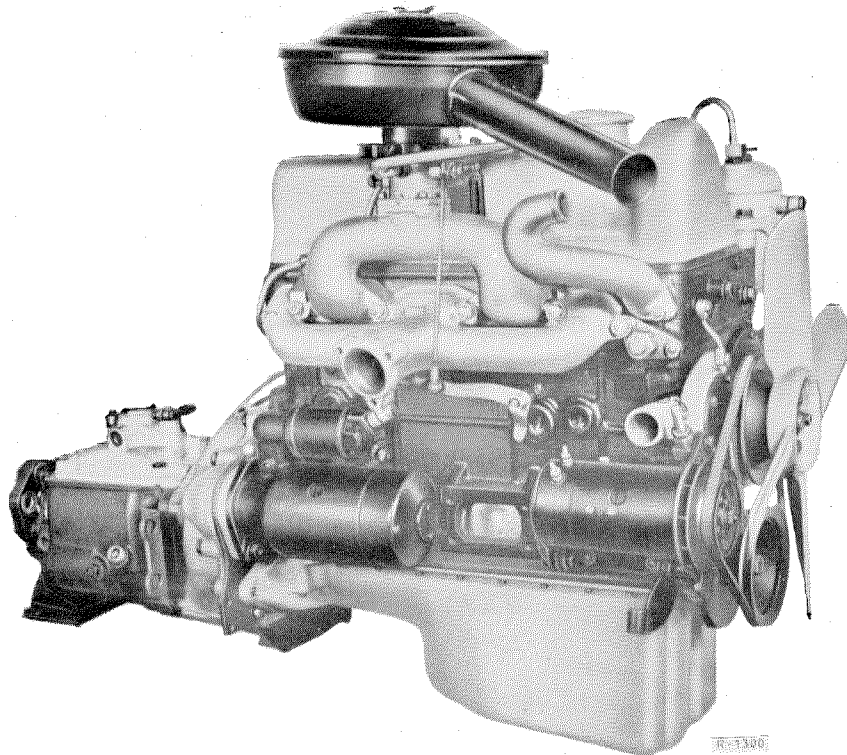
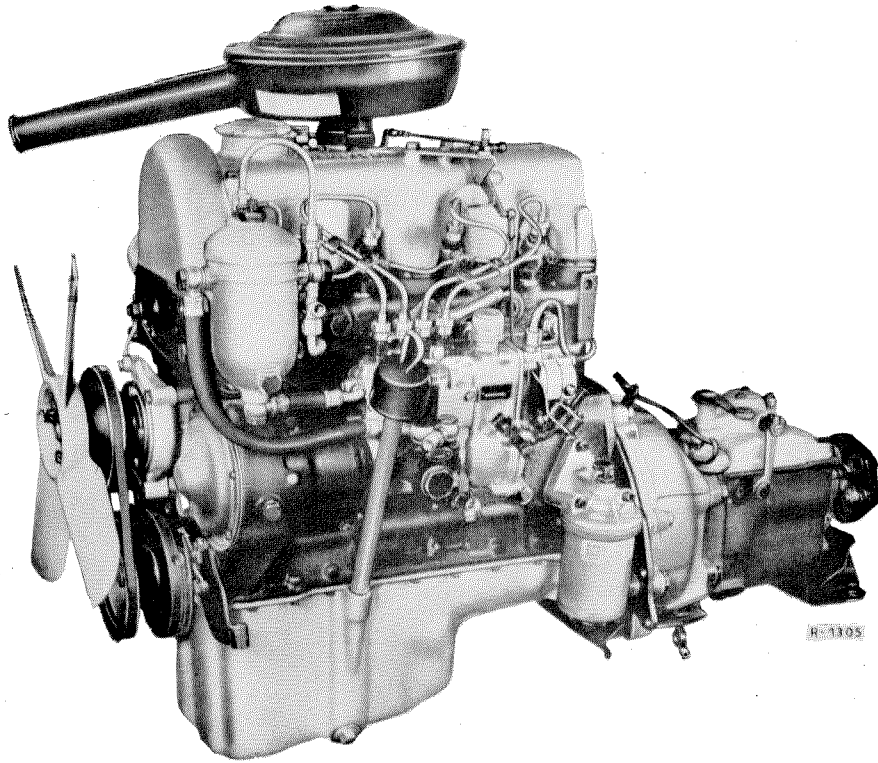

Engine Model OM 621.III, Type 621.912, with Swing Suction Pipe for Vehicle Model 190 Dc

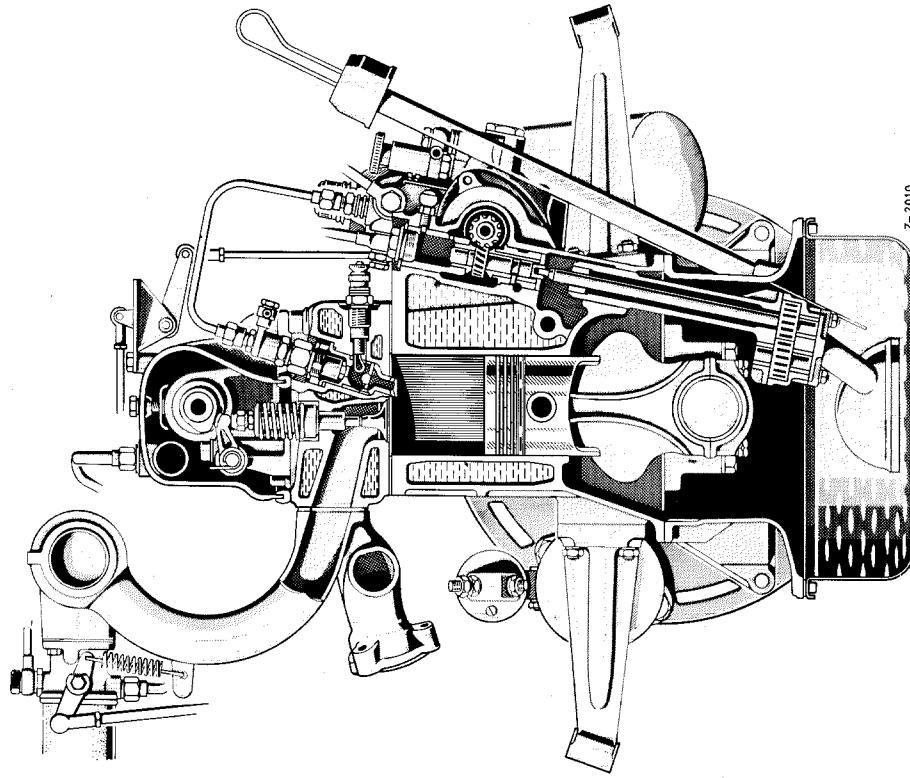

Cross Section
of Engine

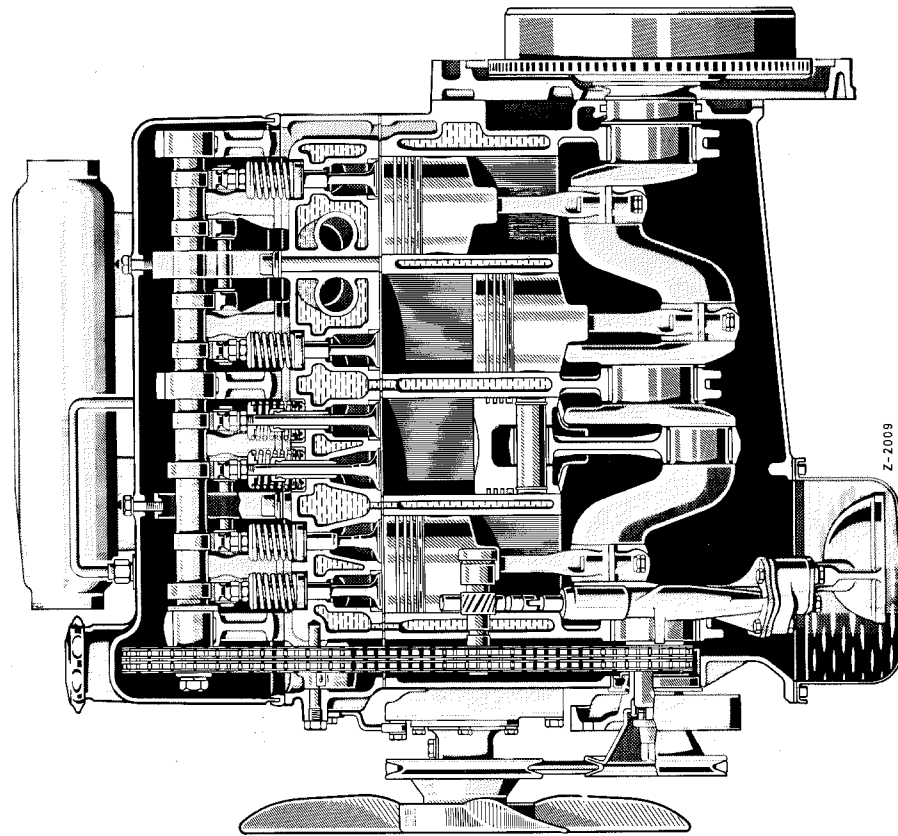

Longitudinal Section
of Engine